

Wellfleet Board of Health
Wednesday November 9, 2022; 5:30pm
Hybrid Meeting ~ Zoom/715 Old King's Highway, Wellfleet
Meeting Agenda

Permits:

- 8 Golden Rod Rd, Wellfleet, MA; Map #8, Parcel #98 ~ Charles and Ashley Rogers ~ Stable Permit Application

Business:

- Targeted Watershed Management Plan
Presentation by Scott Horsley & GHD
- Wellfleet Board of Health Rules and Regulations
Discussion on Draft Changes

Minutes:

- August 10, 2022
- August 24, 2022
- September 7, 2022
- September 14, 2022

Join Zoom Meeting

<https://us02web.zoom.us/j/84903690377?pwd=VDA2Mm1QQXBVcDBENW5vd0hTNGRqdz09>

Meeting ID: 849 0369 0377

Passcode: 918049

Dial by your location

+1 929 205 6099 US (New York)



WELLFLEET BOARD OF HEALTH
 220 West Main Street, Wellfleet, MA 02667
 508-349-0308 Fax: 508-349-0327
 email: hillary.lemos@wellfleet-ma.gov

New
 Renewal

FARM ANIMAL/STABLE PERMIT APPLICATION - 2022

Name Charles and Ashley Rogers Phone 508-237-1986 (Ashley)

Mailing Address 319 Cole Neck Rd. Wellfleet, MA 02667

*** EMAIL: ashleywellfleet@gmail.com

Location Address of Animals 8 Goldenrod Lane

Location of Wells in an area of wells - all wells 100ft + away
 Briefly explain: from horse area

A. Number & Type of Animal(s) 3 Horses

B. Fencing

Type A combination of pressure treated 1'x6', metal no-climb and pipe gates

Distance to Property Lines 25 ft @ closest lot lines

Distance to Wells all wells 100+ ft. away from horse area

C. Plan of Care and Maintenance

Water fresh free hydrants, electric buckets, full access to 20 gallon tub

Vermin Control traps, ultrasonic repellents, no food ever left out.

Manure manure picked up 2 to 3 times daily, put in dump trailer, manure emptied from trailer once a week @ transfer station

A. Housing (describe what applies)

Size of Shelter 24 x 24 garage containing

Grain/Hay Storage galvanized cans, fridge for vitamins 12x12 area for hay

Flooring hard packed sand with thick rubber mats

Light natural, electric

Ventilation cross ventilation thru open doors, electric fans in summer

If applying for a livestock permit, have you received Special Permit from the Zoning Board of Appeals? haven't applied yet Date: _____

Signature Ashley Rogers

Date 9/23/2022

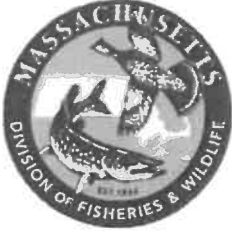

MASSWILDLIFE

DIVISION OF FISHERIES & WILDLIFE

1 Rabbit Hill Road, Westborough, MA 01581
p: (508) 389-6300 | f: (508) 389-7890
MASS.GOV/MASSWILDLIFE

August 19, 2022

Charles & Ashley Rogers
319 Coles Neck Road
Wellfleet MA 02667

RE: Project Location: 8 Goldenrod Lane, Wellfleet
 Project Description: Dwelling with barn and paddock
 NHESP File No.: 22-41291

Dear Applicant:

Thank you for submitting the MESA Project Review Checklist, site plans (dated 8/9/2022) and other required materials to the Natural Heritage and Endangered Species Program of the MA Division of Fisheries & Wildlife (the "Division") for review pursuant to the Massachusetts Endangered Species Act (MESA) (MGL c.131A) and its implementing regulations (321 CMR 10.00).

Based on a review of the information that was provided and the information that is currently contained in our database, the Division has determined that this project, as currently proposed, **will not result in a prohibited Take** of state-listed rare species. This determination is a final decision of the Division of Fisheries & Wildlife pursuant to 321 CMR 10.18. Any changes to the proposed project or any additional work beyond that shown on the site plans may require an additional filing with the Division pursuant to the MESA. This project may be subject to further review if no physical work is commenced within five years from the date of issuance of this determination, or if there is a change to the project.

Please note that this determination addresses only the matter of state-listed species and their habitats. If you have any questions regarding this letter please contact Melany Cheeseman, Endangered Species Review Assistant, at (508) 389-6357.

Sincerely,

A handwritten signature in black ink that reads "Everose Schlüter".

Everose Schlüter, Ph.D.
Assistant Director

MASSWILDLIFE

ENVIROTECH LABORATORIES, INC.

MA CERT. NO.: M-MA 063

8 Jan Sebastian Drive Unit 12
Sandwich, MA 02563
(508)888-6460 1-800-339-6460
FAX (508)888-6446

Client Name : Cappello Well Drilling
Address : PO Box 293
Wellfleet, MA
02867

Location : 8 Goldenrod Ln
Wellfleet MAP8 PCL 98

Collected By : Frank

Lab Number : DW-223953

Date Received : 09/13/22

Sample Type : New Well

Well Specs : Map 8 pcl 98

Location Source A	Date Collected 09/13/22	Time Collected 9:00	Comments			
Analysis Requested	Units	Recommended Limits	Analysis Result	Method	Date Analyzed	Analyzed By
Total Coliform	CFU/100mL	0	0	SM9222B	09/13/2022	KF@1730
pH	pH units	6.5-8.5	6.34	SM 4500-H-B	09/13/2022	RS
Specific Conductance	umhos/cm	500	110	EPA 120.1	09/13/2022	RS
Nitrite-N	mg/L	1.00	<0.008	EPA 300.0	09/13/2022	RS
Nitrate-N	mg/L	10.0	0.089	EPA 300.0	09/13/2022	RS
Sodium	mg/L	20.0	18	EPA 200.7	09/17/2022	KB
Total Iron	mg/L	0.3	0.03	EPA 200.7	09/17/2022	KB
Manganese	mg/L	0.05	0.012	EPA 200.7	09/17/2022	KB

Comments:

pH is below recommended limit and may have corrosive characteristics.
All samples were analyzed within the established guidelines of US EPA approved methods with all requirements met, unless otherwise noted at the end of a given sample's analytical results.
We certify that the following results are true and accurate to the best of our knowledge.

Water meets EPA standards and is suitable for drinking for parameters tested.

Ronald J. Saari
Laboratory Director

Date 9/21/2022



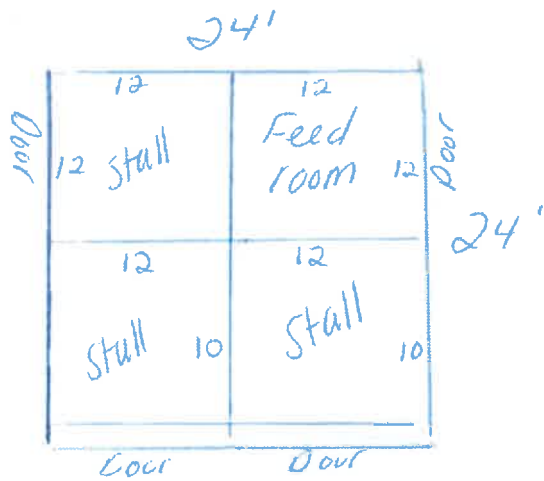





DUMP TRAILER - TR508 - PREMIUM SERIES



SPECIFICATIONS

\$

Model#

TR508L5

GVWR: #	5,000 lbs.
Curb weight: (standard gate)	1,380 lbs.
Payload capacity:	3,620 lbs
Volume: (level)	2.4 cubic yards
Bed size width x length:	59.7" x 95.5"
Deck height:	25"
Tire size:	225/75/15D
Axle capacity:	6000 lbs.
Electric brakes:	Yes
Cylinder bore x length:	3" x 24"
Side height:	21"



Pump & battery box, w/ optional battery tender

STANDARD FEATURES

- * 12 gauge floor/14 gauge side plates
- * 4" tube main frame
- * 3" channel tongue frame
- * Two way tailgate (top/bottom hinged)
- * EZ Lube Dexter axle
- * 10' pendant control cord
- * Lockable pump/battery box
- * LED rubber mounted lighting
- * 7-way RV plug w/ charge circuit
- * 7K safety chain rating (each)
- * 5K top wind post jack
- * 2 5/16" coupler (14K rated)
- * External, 2" x 4" stake pockets
- * DuPont™ Imron® Elite black oven cured paint w/ epoxy primer
- * Two Year Limited Warranty

OPTIONS

- * Radial tires
- * Mesh roller tarp, manual
- * Spare tire mount w/ wheel & tire
- * 12-volt deep cycle battery
- * Battery tender (weatherproof)
- * D-rings, 3/8" diameter, bolt on (for general purpose)
- * 8K drop leg jack (bolt on)
- * Double acting pump (power up / power down)
- * Colors: Blue, Green, Red Grey, Cat Yellow



Sealed LED lights

DownEaster 

120 Old Lisbon RD. - Topsham, ME 04086
(207) 729-5101 - Fax (207) 729-8782

www.downeastermfg.com



Distributed by:

LOCUS MAP

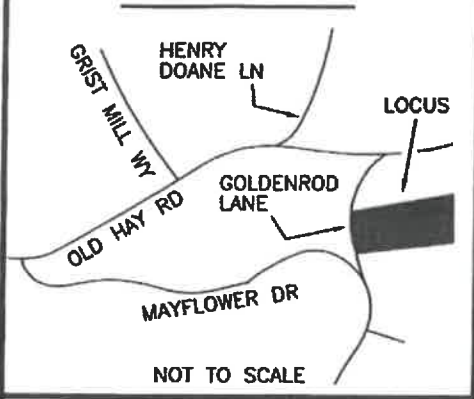

THIS PLAN REQUIRES MESA APPROVAL.
 WORK LIMIT TO BE STAKED SILT FENCE.
 PROPOSED DISTURBED AREA WITHIN WORK LIMIT = 19,224 S.F.± (37.4%)

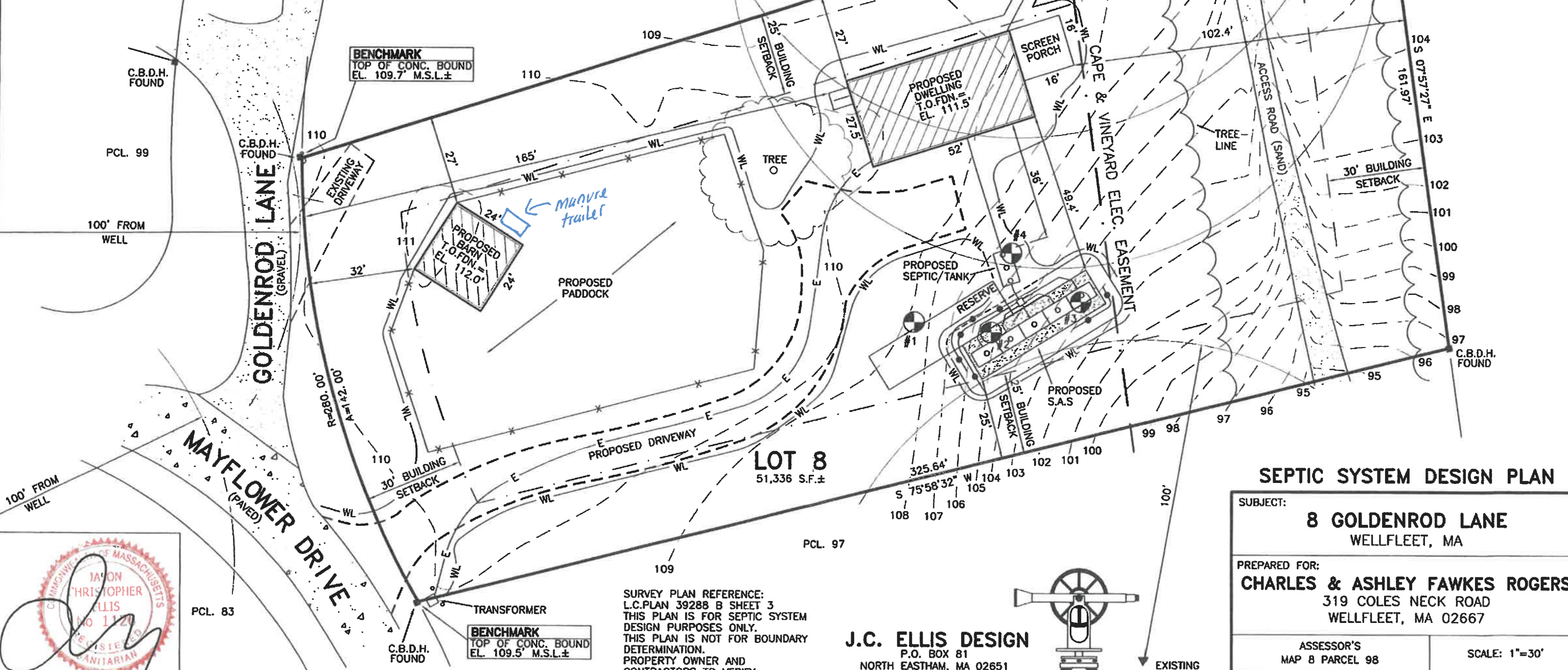
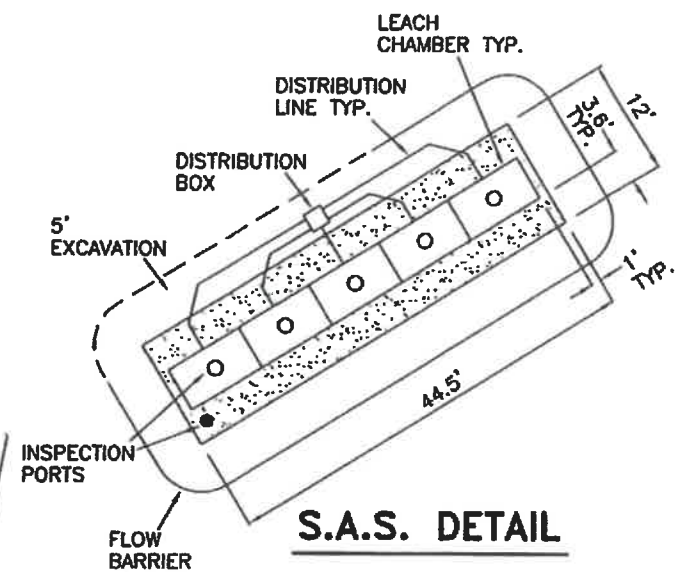

N.P.S. BOUND
 19-31
 FOUND
BENCHMARK
 TOP OF N.P.S. BOUND
 EL. 106.0' M.S.L.±

BENCHMARK
 TOP OF CONC. BOUND
 EL. 109.7' M.S.L.±

BENCHMARK
 TOP OF CONC. BOUND
 EL. 109.5' M.S.L.±

SEPTIC SYSTEM DESIGN PLAN

SUBJECT: 8 GOLDENROD LANE WELLFLEET, MA	
PREPARED FOR: CHARLES & ASHLEY FAWKES ROGERS 319 COLES NECK ROAD WELLFLEET, MA 02667	
ASSESSOR'S MAP 8 PARCEL 98	SCALE: 1"=30'
DATE: AUGUST 9, 2022	SHEET 1 OF 2

SURVEY PLAN REFERENCE:
 L.C.PLAN 39288 B SHEET 3
 THIS PLAN IS FOR SEPTIC SYSTEM
 DESIGN PURPOSES ONLY.
 THIS PLAN IS NOT FOR BOUNDARY
 DETERMINATION.
 PROPERTY OWNER AND
 CONTRACTORS TO VERIFY
 ALL WATER LINES AND GAS
 UTILITIES ON PROPERTY

J.C. ELLIS DESIGN
 P.O. BOX 81
 NORTH EASTHAM, MA 02651
 (508)240-2220
 Email: jason@jcellisdesign.com

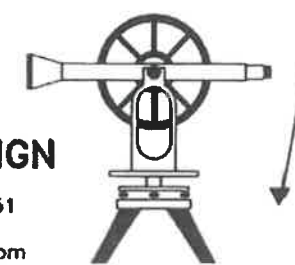

JASON C. ELLIS, R.S.
 MASSACHUSETTS
 LAND SURVEYOR
 No. 1122
 SANITARIAN



DRAFT

WELLFLEET BOARD OF HEALTH REGULATIONS

April 2022

**TOWN OF WELLFLEET
BOARD OF HEALTH REGULATIONS**

CONTENTS:

100	Introduction
200	Administration
300	Definitions
400	Regulatory Process and General Provisions
500	Water Wells
600	Subsurface Sewage Disposal Systems
700	Underground Storage Tanks
800	Swimming Pools
900	Farm Animals
1000	Solid Waste Transfer Station
2000	Massage/Muscular Therapy
2000A	Body Art Establishments and Practitioners
3000	Miscellaneous Regulations
4000	Tobacco Control Regulations
5000	State Regulations
6000	Temporary Regulations
7000	Procedures
8000	Fee Schedule
Attachment A	Recycling

**TOWN OF WELLFLEET
BOARD OF HEALTH REGULATIONS**

As amended 03/07/94, 06/15/00, 7/1/01, 11/14/01, 3/27/02, 2/26/03, 3/26/03, 3/22/06, 9/27/06,
8/7/08, 4/28/10, 5/26/10, 7/11/12, 11/13/13, 4/9/14, 5/11/16, 10/11/17

100 INTRODUCTION

- 101 The following regulations are promulgated under the authority of the General Laws of the Commonwealth. They supplement those provided by the State Building and Sanitary Codes, and those issued under the Wetlands Protection Act, the Water Pollution Control Act, the Wellfleet Floodplain Bylaw, and the Wellfleet Environmental Protection Bylaw. The Wellfleet Board of Health Regulations will prevail when they are more restrictive.
- 102 The following regulations are designed to protect the public health and safety of the residents and visitors, and are based on the particular physical, environmental, hydrogeological, and demographic conditions, and land use information and projections available to the Board as they relate to the Town of Wellfleet. Of specific concern is the need to protect the groundwater, which is the sole source of our drinking water.
- 103 These regulations become effective January 1, 1988 and supercede all previously issued Board of Health regulations, except as noted hereinafter.
- 104 If any section, paragraph, sentence, clause, phrase or word of these regulations shall be judged invalid for any reason, that decision shall not affect any other portion of these regulations which shall remain in full force and effect; and, to this end, the provisions of these regulations are hereby declared severable.

200 ADMINISTRATION

- 201 The Board of Health will make determinations in accordance with these and other regulations, but reserves the right in special circumstances, as determined in its judgment, to be more restrictive, to issue variances, or to grant exemptions. The rationale for such departures shall be documented in written minutes of the Board of Health meeting in question.
- 202 The Health Agent is authorized to act for the Board of Health (1) when an applicant has clearly met all State and Wellfleet requirements, and (2) in emergency situations. At its next posted meeting, the Board of Health is required to ratify or modify as necessary in its judgment, the actions taken and/or decisions made by the Health Agent in such emergency situations.

DEFINITIONS

- 300 With the exceptions listed in 302, the definitions provided in the State Building and Sanitary Codes and the Wetlands Protection Regulations will apply. "Board" shall mean the Wellfleet Board of Health.

301 The following definitions are adopted by the Board for use in administering these regulations and interpreting State laws, regulations and codes.

ABUTTERS Owners of all adjacent properties and properties directly across any public or private highway, road, street or way.

ALTERATION To make different by changing, adding and/or subtracting components, piping, and/or location.

BEDROOM A room providing privacy, intended primarily for sleeping, and consisting of all of the following:

- (a) floor space of no less than 70 square feet
- (b) for new construction or existing houses and mobile homes a ceiling height of no less than 7'0"
- (c) an electrical service and ventilation, and with regard to new construction at least one building code conforming egress window.

The following are not considered bedrooms:

Any "pass through" room that does not afford privacy, a living room or "great" room, a dining room, kitchens, halls, bathrooms, unfinished cellars, unheated storage areas over garages, and loft spaces less than 70 square feet. Any extra rooms (such as a finished basement or playroom with building conforming egress) may be considered a bedroom if it meets the definition. For new construction, proposed renovation, alteration or replacement of structure, conformity to definition criteria is expected; for existing developments, criteria will be applied in context of the vintage of construction. In determining proper design flow where there is no corroborating record of a grandfathered number of bedrooms on file in the Health Department, the calculation will be derived only from presently existing bedrooms in instances where the Nitrogen Loading Limitation is exceeded. Deed restrictions will be required if maximum bedroom allotment is met and homeowner wishes to finish rooms that may appear to meet the definition above.

BUILDABLE UPLAND The area of contiguous upland on a lot exclusive of Wetland

FAILED SYSTEM A failed system is defined as one in which there is evidence of sewage flow or ponding to the surface; evidence of overload of the system; any cesspool as defined in Title 5; the system is in such a state of disrepair that it can not function as originally intended; lack of four (4) foot of vertical separation between the bottom of the system and adjusted groundwater (for a 1978 code system) or a lack of five(5) foot of vertical separation between the bottom of the system and adjusted groundwater (for a 1995 code system); system is composed of leach pit(s) which is inadequate in design or capacity for the existing use; or system requires pumping more than four (4) times in a twelve-month period to prevent such overflows.

FILLED LAND Land whose elevation is being, or has been, raised within the past fifty years by the addition of fill or spoil on the preexisting natural grade.

GRANDFATHERED NON-CONFORMING DWELLING An existing habitable dwelling with a design flow rate that exceeds the nitrogen loading limitations.

MOUNDING Raising the natural elevation or grade of the ground to cover the components of a sewage disposal system, and/or to meet the vertical distance requirements above groundwater.

NEW CONSTRUCTION The construction of a new building for which an occupancy permit is required or an increase in the actual or design flow to any system or an increase in the actual or design flow to any nonconforming system or an increase in the design flow to any system above the existing approved capacity.

NITROGEN LOADING LIMITATIONS The 440 gallons per day per acre nitrogen loading limitations for design of septic systems in Nitrogen Sensitive Areas as designated in Title 5.

NITROGEN SENSITIVE AREAS: Interim Wellhead Protection Areas and Department approved Zone IIs of public water supplies; or Nitrogen sensitive embayments as identified by the Massachusetts Estuaries Project; or other areas which are designated as nitrogen sensitive for purposes of 310 CMR 15.000.

NON CONFORMING SYSTEM Any system which, when installed did not comply with the provisions of either the 1978 or 1995 iterations of Title 5, including cesspools and all similar systems in use prior to adoption of these codes and without a signed/stamped engineered plan

REPAIR To restore to the original condition in the original location by replacing and/or putting together what is damaged or broken.

UPGRADE To alter in such a fashion as to improve performance over that of the system as originally installed.

WATER COURSE A water course shall be defined as a river or spring; a natural channel in which water flows regularly or intermittently; a wetland, vernal pool, lake, pond, or dam into which, or from which, water flows.

WETLAND Any area that contains swamp, bog, dry bog, fresh or salt marsh, areas of exposed groundwater, embayment's, rivers, ponds, streams, inland banks, coastal banks, and coastal dunes, or any other area subject to the jurisdiction of the Conservation Commission as defined in M.G.L. c. 131, Section 40, 310 CMR 10.00, the Wellfleet Conservation Bylaw and the Wellfleet Environmental Protection Regulations excluding the bufferzone and the Area of Critical Environmental Concern.

400 REGULATORY PROCESS AND GENERAL PROVISIONS

- 401 Any project which creates additional bedrooms or commercial space through new construction or by alteration of an existing structure and changes of use of an existing property, must meet both the State Sanitary Code and Wellfleet Board of Health Regulations.
- 402 Plans prepared by a Registered Engineer or by a Registered Sanitarian are required by the Board for consideration of any project or change requiring Board approval.
- 403 Board of Health Well and Disposal Works (Septic System) Construction Permits shall expire three (3) years from date of final variance approval. Any approvals of variances granted by the Wellfleet Board of Health are deemed a contract under which the applicant must perform the upgrade or new construction as proposed. Any failure to execute the plans in a timely manner under the Disposal Works Construction Permit will result in the expiration of variance approvals and enforcement notice to file a revised plan compliant with any new Title 5 or local regulations that have come into effect.
- 404 The following regulation shall apply to all proposed projects comprising six or more dwelling units (existing and/or new) such as hotels, motels, cluster developments, planned developments, subdivisions, nursing homes, and hospitals. Any developer who seeks to discharge septic system effluent to the groundwater from any of the above types of development shall be required to obtain Board approval to do so. A preliminary discussion with the Board of health is recommended to define the specific information needed by the Board in each situation. In the application for Board approval, the information listed below will generally be required:
- A. A water table contour map and geological description of the area in the vicinity of the proposed project, depicting groundwater flow direction.
 - B. Projections of nitrogen levels in down-gradient groundwater and delineation of effluent plumes.
 - C. Projection of the impact on down-gradient water supplies (both present and potential), lakes, ponds, marshlands, estuaries and coastal waters.
 - D. Appropriate water quality information.

The information provided to the Board must demonstrate that no significant impact to down-gradient water resources will occur as a result of the project.

500 WATER WELLS

- 501 A water supply considered acceptable in quality and quantity by the Board of Health is a prerequisite for any project or change requiring Board of Health permission. A water supply shall be deemed acceptable in quality if sodium is not greater than 2000mg/l, nitrate/nitrogen is not greater than 10 mg/l, coliform does not exceed zero and all EPA standards are met.
- 502 If a previous water test is on file and has tested above the allowable limits the Board reserves the right to require a retest at its discretion.

- 503 No well is to be installed without prior issuance of a Board of Health permit. Replacement wells are not excepted. Within seven days after installation, a “Well Construction Record” is to be submitted by the installer to the Board of Health on the form provided.
- 504 Private water wells are to be located on the property served.
- 505 Water wells for new construction of private residences are to be located at least 100 feet from any cesspool or septic system leach field, and at least 50 feet from any catch basin serving a paved area. To the extent feasible, replacement wells are to meet the same criteria. In any event, replacement wells are not to be located closer to the nearest cesspool or septic system leach field than the well being replaced.
- 506 For new construction, water well completion reports must be provided to the Board before a sewage disposal works permit will be issued. Such reports will locate the well installation accurately on the plot plan of the property, and describe the physical characteristics of the well, for example, by providing a well log.
- 507 Only well-drillers licensed by the Commonwealth of Massachusetts may install wells which are to provide water for drinking purposes, irrigation or monitoring.
- 508 A water sample shall be obtained from all drinking wells requiring a permit for analysis by the Barnstable County Health Department or by a State-certified laboratory. The testing shall include as a minimum (1) coliform count, (2) pH, (3) conductivity, (4) iron content, (5) nitrate content, and (6) sodium content. A copy of the analysis report shall be furnished to the Board of Health.
- 509 Whereas there is evidence that the groundwater in the vicinity of the Wellfleet Landfill contains substances which are injurious to human health in the judgment of the Board of Health, and whereas the Board of Health has a responsibility to protect the health of those who obtain their domestic water supplies from such ground waters, and whereas the Cole’s Neck public water supply has been installed whose primary purpose is to prevent any potential health problems arising from the use of such waters, therefore it is prohibited to install and/or use drinking water wells in the Cole’s Neck Area to be Served (ATBS) as defined in the Cole’s Neck Regulations as adopted November 26, 1990 and amended May 7, 1991 and September 24, 2001.
- 510 a) When a property is sold or transferred, a standard water quality test is required by the seller, and a copy is to be provided to the Health Department.
b) Prior to Board of Health signoff on any Certificate of Occupancy, a standard water quality test taken within one year of the request for Certificate of Occupancy and meeting the Federal Drinking Water Standards is required.
c) Prior to issuance of any Disposal Works Construction Permit, a standard water quality test taken within one year and meeting the Federal Drinking Water Standards is required.

511 It shall be unlawful for a commercial entity to employ the use of non-recycled water-dependent displays of merchandise.

512 Bottled water permits will not be allowed for new food service establishments.

600 SUBSURFACE SEWAGE DISPOSAL SYSTEMS

601 Required Upgrades: In order to improve the quality of water for the Town of Wellfleet elimination of septic systems which meet the failure criteria by Title 5 and the Local BOH Regulation definition of failure shall bring nonconforming septic systems into compliance by upgrading them to meet the standards of this section and/ or Title 5 in the following situations:

- A. Prior to any sale or transfer of title to the facility served by the system;
- B. Prior to any change of use or increase in design flow;
- C. Prior to the subdivision or partitioning of a parcel of land on which a nonconforming septic system is located;
- D. If the system demonstrates any of the characteristics of a failed system as defined by these regulations and/ or Title 5
- E. If the septic system serving the facility was not constructed according to an approved stamped plan (i.e. Plan shows distribution box but it is not in the plan);
- F. If the system does not meet the design flow of the facility it serves;
- G. If a facility is replaced, relocated, or demolished;
- H. The liquid depth in a leach pit is less than six inches from the inlet pipe invert or the remaining available volume within a leach pit above the liquid depth is less than ½ of one day's design flow;
- I. All non-conforming septic systems and cesspools within two hundred (200) feet of any wetland or within the floodplain as mapped by FEMA
- J. Cesspools in Wellfleet are herein defined as failed systems and shall be upgraded to meet the requirements of Title 5 prior to December 31, 2024. All new systems replacing cesspools shall be installed and issued certificates of compliance by December 31, 2024.

602

Multiple Systems on One Lot: In the event of the failure of one septic system on a lot that has more than one non-conforming septic system, the failing system shall be immediately upgraded and the remaining non-conforming septic system shall also be upgraded to meet the requirements of the 1995 Title 5 code and these regulations within one years' time. If the design flow for the facility is over 2000 gallons per day, pressure distribution must be used.

603

Sewage Disposal Works Construction Permits will be issued when the proposed system fully meets the physical (i.e. hardware and spatial) requirements of the State Sanitary Code (Title 5), and the following specific requirements of the Wellfleet Board of Health:

- A. The leaching field must be at least 100 feet, and the septic tank at least 50 feet, from any water-course.

- B. The septic tank and the leaching facility must be at least 1 foot below the existing natural grade when in the 100 year floodplain.
- C. A minimum 1500 gallon septic tank is required for single family dwelling units.
- D. Inspection and approval by the Board of Health or its Agent at the time of installation is required by the Board.
- E. The applicant must provide evidence that the property to be served by the system has an acceptable water supply before a Sewage Disposal Works Construction Permit will be issued.

604 “As-Built” cards must be filed with the Health Agent prior to final inspection of the system by the contractor. The Board of Health requires certified As-Built plans by the engineer. As-Built cards or plans must accurately depict the installed locations of system components.

605 INSPECTION CRITERIA

Unless inspected previously within two years under the terms of this regulation, the on-site sewage disposal system shall be inspected by a licensed inspector approved by the Board of Health whenever a property containing such a system is transferred by sale, exchange, gift, or bequest to a new ownership, or placed into or taken out of a form of trust ownership; Where there is an application for a special permit that allows uses not otherwise permitted by the Wellfleet Zoning Bylaws; Any changes of use in a property; Application for a new license or transfer of an existing license, renewal of the annual operating permit for the operation of a motel, cottage colony, cabins, campgrounds, lodging houses and restaurants. A copy of the report of such inspection is to be furnished to the Health Department by the prospective new owner prior to the closing, and where an upgrade is required, an agreement specifying the timeframe shall be signed.

Where there is an application for a building permit proposing renovation, replacement or alteration of habitable or accessory area, footprint, or making improvements to structure beyond minimal expense, a septic inspection will be required to determine if an upgrade is needed. A copy of the report of such inspection is to be furnished to the Health Department by the permit applicant prior to the Health Agent’s approval for any building permit. Exemptions from this provision are involuntary repairs necessary to maintain structural integrity or minimum standards of habitation, such as framing, window and roofing repairs / replacements or evidence in Health Department files that the septic system was installed within the past ten years, according to the date of the building permit.

In addition to the inspection criteria set forth in Title 5, the following criteria shall be observed in conducting system inspections:

- A. An open inspection of all components of the system. If a component can not be found or uncovered after a reasonable search, the inspector must provide evidence for the system’s success or failure. Replacement or installation of the component is required in this instance.
- B. The septic tank shall be pumped at the time of inspection if it has not been pumped within the past three years.

- C. Leach pits must have 6 inches of leaching capacity below the outlet invert in order to pass the inspection. The 6 inches of leaching capacity is determined by clean sidewall absent of staining or evidence of high water.
- D. The inspector must clearly indicate on the inspection form the height of standing liquid and the level of staining in any leaching component, and the description of both sanitary tees in any inspected tank.
- E. Any work for correction of component failures must be done under benefit of a disposal works construction permit.
- F. If the inspector finds that access ports/ inspection port covers are not within six inches of grade, risers shall be provided and installed and shall be indicated on the inspection report submitted.
- G. Vertical separation to groundwater shall be confirmed and measured in in the field and documented on the Title 5 inspection report. The groundwater adjustment shall also be evaluated and shown on the report.

The Health Department shall promptly evaluate all such inspection reports received and determine whether or not it requires, within six (6) months from the date of closing or within two years from the date of issuance of any building permit, an upgrade of said disposal system to meet Title 5 and Town regulations to the extent feasible. A system that passes inspection shall be deemed to have met the standards of Title 5 that were in place when the system was permitted, with the exclusion of vertical separation to groundwater standards that may have existed prior to the 1978 version of the Title 5 code.

In making its determination, the Health Department and the Board of Health shall consider the following:

- (1) vertical separation between the bottom of the leaching facility and adjusted observed groundwater meets the minimum of 4 feet for existing 1978 code systems and 5 feet for 1995 code systems,
- (2) setbacks to septic systems and wells in the neighborhood,
- (3) setbacks to wetlands and local requirements for denitrification,
- (4) evidence of overflow, hydraulic loading, breakout, filling, or a deviation from the approved plan,
- (6) pumping records,
- (7) leaching capacity of existing systems relative to potential need.
- (8) Nitrogen loading on pre-existing nonconforming lots

This regulation shall not be effective at the conveyance or device of the property to the surviving spouse or, in the case of joint ownership, if the property is conveyed to one of the original owners.

Under these local regulations, a cesspool system serving any property shall be defined as “failed” and must be upgraded to meet Title 5 standards within 6 months of property transfers of any device, and within two years of the issuance of a building permit, or any self-identification associated with a septic inspection or by December 31, 2024.

Systems that have been previously determined to be failed and are under enforcement from the Board of Health must be upgraded prior to property transfer or money to accommodate such upgrade shall be placed into an escrow account. The Board of Health must be provided written evidence of such account. The upgrade must take place within 30 days of property transfer.

606 The addition or application of any chemical or biological agent for the purpose of cleansing or rejuvenating on-site cesspools or septic systems is prohibited except where approved by the DEP.

607 Systems judged by the Health Agent to have failed must be upgraded to meet existing State and local requirements. Systems that are a threat to the public health must be repaired immediately.

608 Required Setbacks for System Components

Notwithstanding the provisions of 310 CMR 15.00 all systems shall conform to the following minimum setback distances for septic tanks and soil absorption systems (SAS), including reserve areas, as measured in feet and set forth below:

	Septic Tank or Pump Chamber	SAS
Surface Water (excluding Wetlands)	50'	100'
Wetlands (including Floodplains)	100'	150'
Ponds	100'	150' or greatest
maximum distance available		

609 Innovative/ Alternative Technology

The use of a nitrogen reducing system (Nitrogen reducing systems are defined as those systems technologies approved by MADEP and rated at 19 mg/liter nitrogen) is required when there is:

- A. a variance to the required 100 feet separation between a drinking water supply well and a soil absorption system,
- B. when a soil absorption system is located less than 100 feet from any wetland resource area
- C. for nitrogen credit applications
- D. for upgrade of non-conforming systems as determined by the Board of Health
- E. for upgrades of previously approved systems that exceed current nitrogen loading standards of 110 gpd/10,000 square feet of lot area
- F. In Nitrogen Sensitive Areas as determined by MA Estuaries Project
- G. in certain cases where a variance is required and circumstances support the use of I/A to mitigate the environmental impact of the proposed system, as determined by the Board of Health

- H. for all new construction, repairs, all property transfers and upgrades within the Wellfleet Harbor Embayment System watersheds as identified by the Massachusetts Estuaries Project (MEP) report (2017).

The use of an Enhanced nitrogen reducing system (those technologies that have average nitrogen effluent concentrations less than 10 mg/liter or demonstrate a net average nitrogen removal rate of 75% or greater as demonstrated by third-party testing) is required when:

- A. Compliance with nitrogen loading limitations cannot be met and the loading rate exceeds 440 gpd/acre
- B. for all new construction, repairs, all property transfers and upgrades within the Wellfleet Harbor Embayment System watersheds as identified by the Massachusetts Estuaries Project (MEP) report (2017).

Variances to this section may take into account the following mitigating factors: direction of groundwater flow, topography, soil conditions, well depths, water quantity/availability, water quality of the locus and surrounding lots, and feasible location of structure and septic system.

Any property served by an innovative/alternative or enhanced system, or recirculating sand filter system approved by the Board of Health shall have notice of the presence of this system recorded on the property deed at Barnstable County Registry of Deeds.

Non-Performance of Innovative/Alternative and Enhanced Technology Systems

- A. Non-performance includes any system that has been determined to be failing to protect public health and safety and the environment, or a system with equipment failure or an unresolved alarm event, or components that are not functioning as designed, or components that are not functioning in accordance with manufacturers specifications, or a system that is in violation of the terms of its approval from the Board of Health.
- B. Non-performance requires written notification to the Board of Health within 1 week from receipt of a lab result, along with a remediation plan with outlined corrective actions to be taken.
- C. Corrective actions must be taken within two weeks of BOH notification to address performance that does not meet the standards of approval.
- D. Lab results showing an exceedance of TN triggers a retest following the corrective actions to demonstrate that the system is back in compliance with applicable standards.
- E. Failure to comply with this process may result in a written warning from the Health Department followed by possible fines and a hearing with the Board of Health that must be attended by the property owner and licensed inspector.

- 610 As allowed under M.G.L. Ch. 111 sec. 31, the Board of Health of the Town of Wellfleet hereby requires that owners and operators of all innovative/alternative sewage treatment technologies and all systems where the soil absorption system is designed for pressure distribution of effluent must report the results of all operation, maintenance, and monitoring activities to Barnstable County Department of Health and Environment. Such reporting must be performed in the manner specified by Barnstable County Department of Health and Environment and must occur within 30 days after each maintenance or monitoring event. Further, when a system operator performs a system inspection and finds that a sewage treatment technology has malfunctioning components which have compromised the system's ability to treat sewage as designed, the operator shall report on the system's status and any planned corrective actions to the Board of Health and Barnstable County Department of Health and Environment within 48 hours of inspection.
- 611 In order to specifically apply the nitrogen loading limitations of 310 CMR 15.214(1) to land area available for recharge, the Board of Health shall only consider buildablepland in order to calculate nitrogen loading limitations.
- 612 Tight tanks will not be permitted when it is feasible to site and construct a Title 5 compliant upgrade for a seasonal or year round residential structure. Tight tanks will only be permitted when the Board of Health determines that a sufficiently compliant Title 5 system is not feasible due to excessive variances from state and local regulation.

700 UNDERGROUND STORAGE TANKS

- Underground tanks used for the storage of gasoline, fuel oil, diesel oil, kerosene, antifreeze, chemicals and other toxic liquids represent a major threat of contamination to the groundwater. The owner of a storage tank that leaks or overflows, and the owner of the property on which it is located, are responsible for cost of decontamination and are potentially liable for any damages resulting from such occurrences. These costs can be very substantial. It is the intent of these regulations to minimize the threat of groundwater contamination from underground storage tanks. Any person having first knowledge of significant leaks or spills of the above-mentioned liquids is required to report the matter immediately to the Board of Health. Guidelines, which are part of these regulations, are available from the Board of Health for reference by persons affected by these regulations. These guidelines will be used by the Board in administering these regulations and are based on the Barnstable County Health and Environmental Department Model Underground Storage Tank Regulations and associated backup material.
- 701 Owners of any such underground storage tank on their property, the primary purpose of which is to serve the needs of a private residence or business, are required to remove said tank(s) by December 31, 1997.
- 702 Installation of underground gasoline, fuel and other chemical storage tanks on residential sites is prohibited.

703 Such underground storage tanks, not regulated in 701, are subject to the following regulations:

- A. They must be registered with the Board of Health when installed or replaced.
- B. They may be installed only if secondary confinement and an approved in-tank or interstitial space monitoring system is provided.
- C. They must be tested 15 years after installation and annually beginning with the 20th year after installation. Test procedures are to conform to 527 CMR 9.18 (7) and be approved by the State Fire Marshal.
- D. They may not be installed any closer than 800 feet from a public or community water supply.

704 No commercial or residential storage tanks may be removed without first obtaining an Underground Storage Tank Removal Permit for the Fire Department.

705 At time of property transfer all above ground tanks (any tank used to store fuel oil for the purpose of heating) shall be required to be replaced with double walled fuel oil storage tanks or shall be required to provide 110% containment capacity to prevent contamination from leaks that may occur. Exterior fuel oil storage tanks must be covered with substantial impermeable construction material to prevent water accumulation within containment in such a way that it satisfies the Board of Health and the Fire Department. The area beneath the exterior tank shall be a 4 inch thick continuous concrete slab. All above ground elements of a fuel storage system shall be maintained free of leaks and visible rust. (Effective 9/22/06)

706 All new construction where above ground fuel storage tanks are installed (inside & outside) shall be required to provide a double walled fuel oil storage tank or shall be required to provide 110% containment capacity to prevent contamination from leaks that may occur. Exterior fuel oil storage tanks must be covered with substantial impermeable construction material to prevent water accumulation within containment in such a way that it satisfies the Board of Health and the Fire Department. The area beneath the exterior tank shall be a 4 inch thick continuous concrete slab. All above ground elements of a fuel storage system shall be maintained free of leaks and visible rust. (Effective 9/22/06)

800 SWIMMING POOLS

801 Installation of an in-ground pool or a pool under permanent cover requires permission of the Board of Health. In general, the Board will require plans to scale showing the exact location of the pool relative to buildings, property lines, and other permanent features. The setbacks and clearances therefore must be adequate in the opinion of the Board, considering the circumstances of each individual situation. New pool installations are to include drywells for use when the pool is drained.

802 Access to residential pools shall be controlled through fencing, locking gates, landscaping, etc. in order to prevent access by the general public. Commercial pools are regulated by the state.

803 When emptying the pool, water shall be drained into an installed drywell, or disposed of in a manner approved by the Board prior to the pool being filled.

804 An annual operating permit from the Board of Health is required for non-residential pools, i.e. those associated with hotels, motels, lodging houses, clubs and other commercial enterprises, whether for profit or not. Depending on the circumstances of the individual case, conditions may be attached to the permit which will impose operating procedures such as cleaning, filter changing, water purification, or testing, and other measures intended to guard public health and safety.

900 FARM ANIMALS

In view of Wellfleet's intent at remaining a rural town (per Article 54, voted at the April 1987 Town Meeting), the keeping of farm animals is allowed when and as permitted by the Board of Health at sites which meet zoning requirements. Conditions may be attached by the Board to any permit issued, which will take into consideration and/or regulate the following:

- A. The kind and number of animals to be kept.
- B. The intensity of development at the site of keeping.
- C. The potential for nuisance factors to abutters and the general public.
- D. Environmental and water supply concerns, and any other factors which may relate to public health and safety.
- E. The animal(s) is to be properly fed, watered and sheltered; fencing is to be adequate so as to contain the animal; manure is to be removed from pens, stables and corrals on a daily basis; the animal and any compost pile are to be maintained so as to minimize odor, flies and rodents; manure is to be composted and no raw manure is to be used on the property; a plan for composting and storing manure is to be submitted to the Health Department for approval; the permit is subject to annual review. For permits granted to keep larger animals (horses, ponies, donkeys, mules, sheep, cattle, swine, or goats) in variance to the minimum lot size of three quarters of an acre, a standard well water test must be submitted annually, except where property is served by public water supply. Health Agent reserves the right to administer the water test in the event that potability is in question.

901 A new permit application shall be accompanied by a standard well water test taken within a year, except where property is served by public water supply. A permit to keep farm animals must be obtained from the Board of Health by any person wishing to keep one or more horses, ponies, donkeys, mules, sheep, cattle, swine, goats, or a gaggle or more than 3 fowl such as chickens, geese, turkeys, ducks and the like. The permit shall be issued for a period of up to one year and shall have conditions attached as deemed appropriate by the Board. Such permits may be renewed, but in granting a renewed permit, the Board reserves the right to add, modify, or remove any conditions(s) attached to the expiring permit as deemed appropriate in the Board's judgment such as requesting an updated well water test where inspection of site conditions vary significantly from approved plans on file in a manner that suggests inadequate well protection.

- 902 Permits to keep one or more horses, ponies, donkeys, mules, bovines or other large animal will be granted (1) only after a public hearing of which abutters will have been legally notified in advance, and (2) only if the applicant has by deed, easement, and/or lease at least three-quarters of an acre (30,000 square feet) under his/her control at the site of the keeping of said animal(s).
- 903 The annual Permit to Keep Farm Animals shall run from January 1st to December 31st.
- 904 Owners of horses, ponies, donkeys, mules, bovines or other large animals must provide the Board of Health with evidence that the animal(s) has/have been vaccinated in accordance with all State requirements, when application is made for a Permit to Keep Farm Animals or a renewal thereof.
- 905 To preclude pollution of shellfish and recreational waters, the keeping of domestic waterfowl within 100 feet of any body of water is prohibited. All domestic waterfowl shall be penned.

1000 SOLID WASTE TRANSFER STATION

Authority: The following rules and regulations are promulgated under the authority of Chapter 111, Section 150A of the Massachusetts General Laws; the Wellfleet Charter, Chapter 5-7-2; and Wellfleet Board of Health Regulations.

Purpose: The Transfer Station is operated and maintained by the Town of Wellfleet for disposal of acceptable waste and recyclable materials which are generated within the boundaries of the Town of Wellfleet. All refuse and other wastes originating outside the Town's boundaries are prohibited.

1001 Access to the Solid Waste Transfer Station

1. The Transfer Station will be open seven (7) days a week from the Friday before Memorial Day to the first Tuesday after Labor Day.
2. The Transfer Station will be open five (5) days a week starting the first Tuesday after Labor Day until the Friday before each Memorial Day. The Transfer Station will be closed on Wednesday and Thursdays during this period.
3. The Transfer Station will be CLOSED on New Year's Day, Martin Luther King Day, Presidents Day, Easter Sunday, Patriots Day, Fourth of July (unless it falls on a Saturday), Columbus Day, Veterans Day, Thanksgiving Day, and Christmas Day.
4. Hours of operation are from 8:00 a.m. until 4:00 pm for solid waste disposal.
- 4a. Hours of operation are from 8:00 am until 3:30 pm for recycling.
5. All vehicles must have a valid Wellfleet Transfer Station sticker to dispose of solid waste. Visitors or residents who do not have a valid sticker may pay a one-time user fee. Proof of stay in Wellfleet may be required upon purchase.

6. All owners, operators, or persons in charge of a vehicle shall upon request submit evidence or answer questions concerning the origin or nature of the materials being disposed of.
7. In order to determine the acceptability and origin of such, all materials being disposed of at the Transfer Station are subject to inspection by the DPW Director or his/her designee.
8. Children under twelve years of age are not permitted out of vehicles at the Transfer Station.
9. Animals are not permitted outside of vehicles while in the facility
10. Persons wishing to purchase a Transfer Station sticker during the last four months of the fiscal year shall be charged at the rate of \$15.00.

1002 Operation of the Transfer Station

1. The Director of the Department of Public Works (DPW) will take all necessary steps to ensure an effective level of facility operation and service.
2. The Director of the DPW or his/her designee may, at his/her discretion, close the Transfer Station when there is an equipment problem, or any other problem that makes transfer of refuse not feasible, or that may result in a health hazard.
3. All vehicles discharging refuse must stop at the gatehouse prior to unloading materials.
4. All materials accepted at the Transfer Station shall be placed in only those areas designated by the DPW Director or his/her designee.
5. The following items are prohibited from disposal into the refuse trailer:
 - a) Brick, concrete, sheetrock, rock, sand, dirt, liquids of any composition, tree stumps or large timbers.
 - b) Metals, auto parts, motors, engines, closed containers, gas cans, tires and appliances. Not acceptable are any metal, glass, or plastic beverage containers that are returnable.
 - c) Any item over four feet long or twelve inches in diameter when rolled up or coiled, such as carpets, carpet pads, wood, snow fencing, chains, mattresses, etc.
 - d) Large bulky items over two feet square of any material.
 - e) Long stringy material such as magnetic tape, metal banding, or a dedicated load of rags.
 - f) Hazardous or toxic materials of any kind. This includes batteries, paint, solvents, motor oil, gasoline, explosives, sewage, chemicals, household cleaning fluids, hospital or biological waste, animal or human waste, nuclear or radioactive material, pesticides, fungicides, toxic materials utilized by artists and crafts people, etc.
 - g) Combustible or non-combustible fluids of any type or composition.

Any questions regarding disposal of these materials should be directed to the DPW Director or the Transfer Station attendants.

5. A minor amount of non-combustible material such as metal or glass food containers may be present.

6. Waste material generated by food establishments, municipal, professional and commercial offices, retail stores, etc. is limited to those items that are combustible and conform to the dimensional restrictions in Section 1002.5.
7. Any unacceptable material found in any load will result in the rejection of the entire load, and/or will be subject to fine in accordance with Section 7003 of Wellfleet Board of Health Regulations.
8. Ordinary household waste that is generated in a single-family dwelling will be accepted with a valid residential Wellfleet Transfer Station sticker and must be in specific Wellfleet designated "Pay as You Throw" bags (Effective 12/1/13). Residential waste may also be accepted with payment of a one time user fee.
9. Solid waste and recycling from hotels, motels, restaurants, and commercial businesses are required to be delivered in a vehicle with a commercial Wellfleet Transfer Station sticker. All solid waste material will be assessed a fee based on the net weight of the load or must be in Wellfleet designated "Pay as You Throw" bags (Effective 12/1/13).
10. All residential waste material brought into the Transfer Station by a commercial refuse hauler, licensed by the Wellfleet Board of Health, must be in a vehicle with a commercial Wellfleet Transfer Station sticker and must be in Wellfleet designated "Pay as You Throw" bags (Effective 1/1/14).
11. No unauthorized dumping, salvaging or foraging within the confines of the Transfer Station is permitted. This applies to residents of Wellfleet and to employees of the Town.
12. Restrictions on the use of the Transfer Station are as follows:
 - a) Yard waste will be accepted with a valid sticker and must be cut into sections no greater than six feet in length and two inches in diameter. No exceptions will be allowed. Brush will not be accepted from any landscapers, builders, or commercial entities.

NOTE: Permits for burning brush on one's own property may be obtained at a nominal fee from the Fire Department during the period of January through April.

- b) No stumps or logs will be accepted.
- c) No automobiles will be accepted.
- d) Metal only will be accepted in the scrap metal pile.
- e) Disposal of tires from garages, service stations, and commercial enterprises is prohibited.
- f) Bulk metal, auto parts, motors, or engines are acceptable but subject to applicable fees.
- g) Boats will be accepted with a valid sticker as follows: metal boats, maximum length 16 ft. Wooden or fiberglass boats must be broken down into pieces no greater than 6 ft. in length or width, and disposed of in the construction pile, with payment of applicable fee. All metal hardware must be removed.
- h) It is the responsibility of the hauler to see that all items being discarded shall be cut to size and stripped of rubber, metal, oil or other materials and discarded in specified areas.

- i) Used oils will be accepted from Wellfleet residents with a valid sticker (no garages or commercial entities). Used oil may not be mixed with chemicals, solvents, paints, or toxic materials. See the attendant on duty for access to the waste oil tank and/or any questions.
 - j) Disposal of any waste originating from outside the Town of Wellfleet is strictly prohibited.
14. No refuse, household trash or large discarded items are to be left at the Transfer Station gate, or deposited on any road, wetland, or vacant property within the Town of Wellfleet. It is contrary to State law and to local bylaws and regulations to use any property other than the Transfer Station for the storage of refuse or discarded items of any size or type.

1003 Recycling

- 1. Refer to Attachment A for information regarding materials that must be recycled and how to prepare them for delivery to the Transfer Station.
- 2. Noncommercial vehicles without a valid Transfer Station sticker that are driven by residents, non-resident taxpayers, or visitors of Wellfleet will be admitted to the Recycling Area of the Transfer Station for the sole purpose of depositing acceptable items for recycling. This does not include access to the Swap Shop.
- 2a. Disposal of any recycling from outside the Town of Wellfleet is strictly prohibited.
- 3. The Town will maintain a Swap Shop for the use of Wellfleet residents only. At all times, items to be left off at the Swap Shop are subject to approval of the attendant on duty. Items must be in at least fair and reusable condition. Appliances and other bulky items may be subject to the normal fee for those items. Proof of residency in Wellfleet will be required.
- 4. As a service to the community and to support recycling, the Transfer Station will provide space for a Salvation Army and/or Goodwill collection box.
- 5. An area at the Transfer Station will be provided for non-profit organizations to place bins for the collection of refundable beverage containers.

1004 Construction and Demolition Waste

- 1. The Transfer Station will accept the following items for the construction & demolition area. These items will incur a separate fee (refer to current fee schedule), and a valid Transfer Station sticker is required.
 - a) Construction waste, including sheetrock, bricks, asphalt and wood shingles, windows, doors and scrap lumber which is cut into six-foot lengths.
 - b) Mattresses, box springs, sofas, chairs and other furniture, carpets.
 - c) Other bulky items subject to approval of the DPW Director and/or the attendant on duty.

1005 Stickers are valid from the first day of July until the last day of June of the succeeding year.

1. The Fee Schedule for the Wellfleet Transfer Station is to be reviewed annually, prior to June 1st, by the Board of Health with input from the Director of the Department of Public Works.

2. Payment on billed accounts are due by the 15th of each month. After one week, an interest rate the same as the current rate charged by the Tax Collector may be applied to any unpaid balance. After fourteen (14) days of non-payment, the permit to use the Transfer Station will be suspended by the Health Agent with written notification to hauler and Board of Health until past due payment has been made in full, including interest accrued. If a permit is suspended all future payments will need to be made at time of disposal.

3. Disputes involving disposal receipts must be made in writing to the Health Department and received within seven calendar days of dumping. If not disputed, all waste disposal fees will be presumed valid and payable within the normal billing period.

4. Delinquent payments may result in a Board of Health hearing to consider a prepayment requirement or permanent revocation of license.

1006 If a dispute arises as to the interpretation, application or enforcement of any of the preceding regulations, then the Director of Public Works or his/her designee will adjudicate. If the dispute cannot be resolved to the satisfaction of both parties, a hearing with the Board of Health may be scheduled. Decisions of the Board of Health may only be disputed as a civil matter in a court of competent jurisdiction.

1007 Whoever violates for any reason any provision of these rules and regulations as defined in Sections 1001.0 through 1006.0 shall be punished by a fine in accordance with Section 7003 of the Wellfleet Board of Health Regulations.

1008 If any section, paragraph, sentence, clause or phrase of these rules and regulations should be ruled invalid for any reason whatsoever, such decision shall not affect the remaining portions of these rules and regulations, which shall remain in full force and effect; and to this end the provisions of these rules and regulations are hereby declared severable.

1000A COMMERCIAL REFUSE COLLECTION

1001A

All persons collecting refuse in Wellfleet providing subscription service to households otherwise eligible for the town's solid waste and recycling program must provide trash and recycling at one bundled price. Residents subscribing to private waste collection shall not have the option of paying for trash collection service only at a lower price.

2000 RULES AND REGULATIONS GOVERNING THE PRACTICE OF MASSAGE AND/OR MUSCULAR THERAPY

2001 The following Rules and Regulations governing the licensing and practice of massage/muscular therapy and the operation of an establishment in which massage/muscular therapy is performed are promulgated under the authority of Chapter 111, Section 31 and Chapter 140, Sections 51-53 of the Massachusetts General Laws.

2002 “Massage or muscular therapist” shall mean any person who has been trained in the art of massage/muscular therapy and who has completed a program of instruction in massage/muscular therapy approved by the Massachusetts Board of Education.

2003 No person under the age of eighteen years shall be considered as qualified to be licensed as a massage/muscular therapist.

2004 “Massage/Muscular Therapy” shall mean a method of applying pressure on or friction against, rubbing, kneading, tapping, pounding or stroking parts of the body with the hands and arms; with or without the aid of other devices used manually or electrically activated, such as a vibrator, with or without supplementary aids such as the application of heat or cold, rubbing alcohol, liniments, oils, creams, lotions, powders, or similar preparations; for the purpose of reducing tension, stimulating circulation, and generally providing for an increase in a person’s health and well-being.

2005 The practice of massage/muscular therapy shall exclude any procedures which puncture, pierce, or, in any manner, penetrate the epidermal layer; utilize high-frequency sound (ultra-sonic), or diathermic equipment.

2006 No person shall engage in the practice of massage/muscular therapy, or conduct an establishment for the giving of massage/muscular therapy, or advertise or hold himself/herself out as being engaged in the business/profession of massage/muscular therapy in the Town of Wellfleet without having received a license from the Wellfleet Board of Health.

2007 Any person desiring to practice massage/muscular therapy shall make written application on a form provided by the Wellfleet Board of Health and provide proof of insurance.

2008 a) The application for the original license must include a certified copy of proof of graduation from a school of massage or muscular therapy approved by the Commonwealth of Massachusetts Department of Education,
(b) or, proof of graduation from a school of massage or muscular therapy certified by the Board of Education in the state in which the school is located.
(c) The applicant must show certification yearly that he or she is free of any communicable disease, as set forth by the Department of Public Health in the Commonwealth of Massachusetts, and evidence satisfactory to the Wellfleet Board of health of moral and physical fitness.

2009 The fee for a license to practice massage/muscular therapy shall be set by the Board of Health. This license is renewable on a yearly basis, on the first of January, and is not transferable.

2010 The fee for a license to operate an establishment for the giving of massage/muscular therapy shall be set by the Board of Health and shall expire on December 31st of each year. This license is not transferable.

2011 The licensing provisions of these regulations shall not apply to classes of individuals who, in the performance of their respective professions, may engage in massage/muscular therapy as defined in these Regulations and who are duly licensed to practice their respective professions by and in the Commonwealth of Massachusetts or who are employed in institutions duly licensed by the Commonwealth of Massachusetts, or coaches and athletic trainers acting within the scope of their employment by schools or educational institutions accredited by the Commonwealth of Massachusetts.

2012 Any establishment offering massage/muscular therapy shall apply for a license from the Wellfleet Board of Health on a form so provided. It is the responsibility of the licensee to apply for a renewal prior to the expiration of the existing license.

2013 The operating requirements for an establishment licensed to practice massage/muscular therapy shall adhere to the following operating requirements:

- (a) All rooms shall be well lighted, ventilated, and be maintained in an orderly and sanitary condition.
- (b) Adequate means shall be provided for the cleansing and sterilizing of all instruments and utensils and, where required, for the cleansing and sterilization of the skin or flesh of the patron undergoing therapy.
- (c) Robes, sheets, blankets, and pillowcases which come into direct contact with the skin of the patrons, and all towels and napkins, after being used and before being used again, shall be laundered in such a manner and under such conditions as to ensure effective sterilization.
- (d) No unsterilized part of a vibrator or other mechanical appliance, instrument or device shall be applied directly to the skin of the patron, but the part of the body being treated shall be covered with a clean towel or else the instrument shall be covered in a similar manner.
- (e) No sponge, or stick alum, nor any other article, lotion or powder likely to be unsterile or unsanitary shall be applied to the skin or to any cut or wound.
- (f) Disposable towels and coverings shall not be re-used. Soiled linens and disposable items shall be deposited in separate covered receptacles and shall be disposed of or laundered in an approved sanitary manner as often as necessary.
- (g) Any room used for the purpose of administering massage/muscular therapy must be dedicated to and for such use and must be situated adjacent to a bathroom containing an adequate supply of hot and cold running water.
- (h) Every person licensed to practice massage/muscular therapy shall thoroughly cleanse his/her hands by washing immediately before serving any patron.
- (i) No establishment licensed for the giving of massage/muscular therapy shall be kept open or operate except between the hours of 8:00 a.m. and 9:00 p.m. unless authorized in writing by the Wellfleet Board of Health.
- (j) Operating behind locked doors is held to be in violation hereunder. Any and all establishments licensed and operating under the authority of these Regulations shall

not have any doors to any rooms, exits or entrances of said establishment locked or obstructed in any way so as to prevent free ingress or egress of persons.

- (k) Any establishment permitted to operate under authority of these Regulations shall post in a conspicuous place within such establishment a schedule of hours. The Health Officer shall be notified of such schedule of hours and of any changes in such schedule. Such establishment shall be open and accessible for inspection during business hours by agents of the Massachusetts Department of Health, or any member of the Wellfleet Police Department, the Fire Department, the Health Officer, or any member of the Town Licensing Authority as provided in MGL, Chapter 140, Section 52.
- (l) All persons in such establishment engaged in the practice of massage/muscular therapy shall hold a valid license from the Wellfleet Board of Health.
- (m) Every person licensed to practice massage/muscular therapy or to operate an establishment for the giving of massage/muscular therapy will be issued a certificate to that effect which will bear the signature of the licensee and the licensee shall have these certificates in his/her possession or posted on a wall, whichever is applicable, whenever or wherever he/she may be engaged in the practice of massage/muscular therapy, and when requested, shall show such certificate to any legally authorized public official.

2014 Massage/Muscular Therapy may be administered on request to ill, infirm, disabled persons or persons without transportation at their legal residence within the Town of Wellfleet by a therapist licensed to practice massage/muscular therapy in the Town of Wellfleet and who holds a license to do business in the Town of Wellfleet.

2015 Massage/Muscular Therapy, when administered outside of a duly licensed establishment within the Town of Wellfleet, is subject to the same rules and regulations that apply to the practice of massage/muscular therapy in an establishment holding a license to do business in the Town of Wellfleet.

2016 Whoever violates for any reason any provision of the Rules and Regulations defined in paragraphs numbered 3200 through 2015 shall be punished by a fine of not more than one hundred dollars (\$100.00) or imprisonment for not more than six months or both in accordance with MGL, Chapter 140, Section 53.

2017 If any action, paragraph, sentence, clause or phrase of these Rules and Regulations should be ruled invalid for any reason whatsoever, such decision shall not affect the remaining portions of these Regulations, which shall remain in full force and effect; and, to this end, the provisions of these Regulations are hereby declared severable.

2000A RULES AND REGULATIONS FOR BODY ART ESTABLISHMENTS AND PRACTITIONERS

2001A. Purpose

Whereas body art is becoming prevalent and popular throughout the Commonwealth; and whereas knowledge and practice of universal precautions, sanitation, personal hygiene, sterilization and aftercare requirements on the part of the practitioner should be demonstrated to

prevent the transmission of disease or injury to the client and/or practitioner; now, therefore the Board of Health of the Town of Wellfleet passes these rules and regulations for the practice of body art in the Town of Wellfleet as part of our mission to protect the health, safety and welfare of the public.

2002A. Authority

These regulations are promulgated under the authority granted to the Board of Health under Massachusetts General Law Chapter 111, section 31.

2003A. Definitions

Aftercare means written instructions given to the client, specific to the body art procedure(s) rendered, about caring for the body art and surrounding area, including information about when to seek medical treatment, if necessary.

Applicant means any person who applies to the Board of Health for either a body art establishment permit or practitioner permit.

Autoclave means an apparatus for sterilization utilizing steam pressure at a specific temperature over a period of time.

Autoclaving means a process which results in the destruction of all forms of microbial life, including highly resistant spores, by the use of an autoclave for a minimum of thirty minutes at 20 pounds of pressure (PSI) at a temperature of 270 degrees Fahrenheit.

Bloodborne Pathogens Standard means OSHA Guidelines contained in 29 CFR 1910.1030, entitled "Occupational Exposure to Bloodborne Pathogens."

Board of Health or Board means the Board of Health that has jurisdiction in the community in which a body art establishment is located including the Board or officer having like powers and duties in towns where there is no Board of Health.

Body Art means the practice of physical body adornment by permitted establishments and practitioners using, but not limited to, the following techniques: body piercing, tattooing, cosmetic tattooing, branding, and scarification. This definition does not include practices that are considered medical procedures by the Board of Registration in Medicine, such as implants under the skin, which procedures are prohibited.

Body Art Establishment or Establishment means a location, place, or business that has been granted a permit by the Board, whether public or private, where the practices of body art are performed, whether or not for profit.

Body Art Practitioner or Practitioner means a specifically identified individual who has been granted a permit by the Board to perform body art in an establishment that has been granted a permit by the Board.

Body Piercing means puncturing or penetrating the skin of a client with pre-sterilized single-use needles and the insertion of pre-sterilized jewelry or other adornment into the opening. This definition excludes piercing of the earlobe with a pre-sterilized single-use stud-and-clasp system manufactured exclusively for ear-piercing.

Braiding means the cutting of strips of skin of a person, which strips are then to be intertwined with one another and placed onto such person so as to cause or allow the incised and interwoven strips of skin to heal in such intertwined condition.

Branding means inducing a pattern of scar tissue by use of a heated material (usually metal) to the skin, making a serious burn, which eventually becomes a scar.

Cleaning area means the area in a Body Art Establishment used in the sterilization, sanitation or other cleaning of instruments or other equipment used for the practice of body art.

Client means a member of the public who requests a body art procedure at a body art establishment.

Contaminated Waste means waste as defined in 105 CMR 480.000: Storage and Disposal of Infectious or Physically Dangerous Medical or Biological Waste, State Sanitary Code, Chapter VIII and/or 29 Code of Federal Regulation part 1910.1030. This includes any liquid or semi-liquid blood or other potentially infectious material; contaminated items that would release blood or other potentially infectious material in a liquid or semi-liquid state if compressed; items on which there is dried blood or other potentially infectious material and which are capable of releasing these materials during handling; sharps and any wastes containing blood or other potentially infectious materials.

Cosmetic Tattooing, also known as permanent cosmetics, micro pigment implantation or dermal pigmentation, means the implantation of permanent pigment around the eyes, lips and cheeks of the face and hair imitation.

Disinfectant means a product registered as a disinfectant by the U.S. Environmental Protection Agency (EPA).

Disinfection means the destruction of disease-causing microorganisms on inanimate objects or surfaces, thereby rendering these objects safe for use or handling.

Ear piercing means the puncturing of the lobe of the ear with a pre-sterilized single-use stud-and-clasp ear-piercing system following the manufacturer's instructions.

Equipment means all machinery, including fixtures, containers, vessels, tools, devices, implements, furniture, display and storage areas, sinks, and all other apparatus and appurtenances used in connection with the operation of a body art establishment.

Exposure means an event whereby there is an eye, mouth or other mucous membrane, non-intact skin or parental contact with the blood or bodily fluids of another person or contact of an eye, mouth or other mucous membrane, non-intact skin or parenteral contact with other potentially infectious matter.

Hand Sink means a lavatory equipped with hot and cold running water under pressure, used solely for washing hands, arms, or other portions of the body.

Hot water means water that attains and maintains a temperature 110°-130°F.

Instruments Used for Body Art means hand pieces, needles, needle bars, and other instruments that may come in contact with a client's body or may be exposed to bodily fluids during any body art procedure.

Invasive means entry into the client's body either by incision or insertion of any instruments into or through the skin or mucosa, or by any other means intended to puncture, break, or otherwise compromise the skin or mucosa.

Jewelry means any ornament inserted into a newly pierced area, which must be made of surgical implant-grade stainless steel; solid 14k or 18k white or yellow gold, niobium, titanium, or platinum; or a dense, low-porosity plastic, which is free of nicks, scratches, or irregular surfaces and has been properly sterilized prior to use.

Light colored means a light reflectance value of 70 percent or greater.

Minor means any person under the age of eighteen (18) years.

Mobile Body Art Establishment means any trailer, truck, car, van, camper or other motorized or non-motorized vehicle, a shed, tent, movable structure,

bar, home or other facility wherein, or concert, fair, party or other event whereat one desires to or actually does conduct body art procedures.

Operator means any person who individually, or jointly or severally with others, owns, or controls an establishment, but is not a body art practitioner.

Permit means Board approval in writing to either (1) operate a body art establishment or (2) operate as a body art practitioner within a body art establishment. Board approval shall be granted solely for the practice of body art pursuant to these regulations. Said permit is exclusive of the establishment's compliance with other licensing or permitting requirements that may exist within the Board's jurisdiction.

Person means an individual, any form of business or social organization or any other non-governmental legal entity, including but not limited to corporations, partnerships, limited-liability companies, associations, trusts or unincorporated organizations.

Physician means an individual licensed as a qualified physician by the Board of Registration in Medicine pursuant to M.G.L. c. 112 § 2.

Procedure surface means any surface of an inanimate object that contacts the client's unclothed body during a body art procedure, skin preparation of the area adjacent to and including the body art procedure, or any associated work area which may require sanitizing.

Sanitary means clean and free of agents of infection or disease.

Sanitize means the application of a U.S. EPA registered sanitizer on a cleaned surface in accordance with the label instructions.

Scarification means altering skin texture by cutting the skin and controlling the body's healing process in order to produce wounds, which result in permanently raised wheals or bumps known as keloids.

Sharps means any object, sterile or contaminated, that may intentionally or accidentally cut or penetrate the skin or mucosa, including, but not limited to, needle devices, lancets, scalpel blades, razor blades, and broken glass.

Sharps Container means a puncture-resistant, leak-proof container that can be closed for handling, storage, transportation, and disposal and that is labeled with the International Biohazard Symbol.

Single Use Items means products or items that are intended for one-time, one-person use and are disposed of after use on each client, including, but not limited to, cotton swabs or balls, tissues or paper products, paper or plastic cups, gauze and sanitary coverings, razors, piercing needles, scalpel blades, stencils, ink cups, and protective gloves.

Sterilize means the use of a physical or chemical procedure to destroy all microbial life including highly resistant bacterial endospores.

Student/Apprentice Practitioner shall mean any person having accumulated fewer than two (2) years actual experience in the practice of performing body art activities but is in compliance with section (E)(2)(a) & (b) & (E)(3).

Tattoo means the indelible mark, figure or decorative design introduced by insertion of dyes or pigments into or under the subcutaneous portion of the skin.

Tattooing means any method of placing ink or other pigment into or under the skin or mucosa by the aid of needles or any other instrument used to puncture the skin, resulting in permanent coloration of the skin or mucosa. This term includes all forms of cosmetic tattooing.

Temporary Body Art Establishment means the same as Mobile Body Art Establishment.

Three dimensional "3D" Body Art or Beading or Implantation means the form of body

art consisting of or requiring the placement, injection or insertion of an object, device or other thing made of matters such as steel, titanium, rubber, latex, plastic, glass or other inert materials, beneath the surface of the skin of a person. This term does not include Body Piercing.

Ultrasonic Cleaning Unit means a unit approved by the Board, physically large enough to fully submerge instruments in liquid, which removes all foreign matter from the instruments by means of high frequency oscillations transmitted through the contained liquid.

Universal Precautions means a set of guidelines and controls, published by the Centers for Disease Control and Prevention (CDC), as "Guidelines for Prevention of Transmission of Human Immunodeficiency Virus (HIV) and Hepatitis B Virus (HBV) to Health-Care and Public-Safety Workers" in Morbidity and Mortality Weekly Report (MMWR), June 23, 1989, Vol.38 No. S-6, and as "Recommendations for Preventing Transmission of Human Immunodeficiency Virus and Hepatitis B Virus to Patients During Exposure-Prone Invasive Procedures" in MMWR, July 12, 1991, Vol.40, No. RR-8. This method of infection control requires the employer and the employee to assume that all human blood and specified human body fluids are infectious for HIV, HBV, and other blood pathogens. Precautions include hand washing; gloving; personal protective equipment; injury prevention; and proper handling and disposal of needles, other sharp instruments, and blood and body fluid-contaminated products.

2004A. Exemptions

- (A) Physicians licensed in accordance with M.G.L. c. 112 § 2 who perform body art procedures as part of patient treatment are exempt from these regulations.
- (B) Individuals who pierce only the lobe of the ear with a pre-sterilized single-use stud-and-clasp ear-piercing system are exempt from these regulations.

2005A. Restrictions

- (A) No tattooing, piercing of genitalia, branding or scarification shall be performed on a person under the age of 18.
- (B) Body piercing, other than piercing the genitalia, may be performed on a person under the age of 18 provided that the person is accompanied by a properly identified parent, legal custodial parent or legal guardian who has signed a form consenting to such procedure. Properly identified shall mean a valid photo identification of the adult and a birth certificate of the minor.
- (C) The following body piercings are hereby prohibited: piercing of the uvula; piercing of the tracheal area; piercing of the neck; piercing of the ankle; piercing between the ribs or vertebrae; piercing of the web area of the hand or foot; piercing of the lingual frenulum (tongue web); piercing of the clitoris; any form of chest or deep muscle piercings, excluding the nipple; piercing of the anus; piercing of an eyelid, whether top or bottom; piercing of the gums; piercing or skewering of a testicle; so called "deep" piercing of the penis – meaning piercing through the shaft of the penis, or "trans-penis" piercing in any area from the corona glandis to the pubic bone; so called "deep" piercing of the scrotum –

meaning piercing through the scrotum, or “transcrotal” piercing; so called “deep” piercing of the vagina.

- (D) The following practices hereby prohibited unless performed by a medical doctor licensed by the Commonwealth of Massachusetts: tongue splitting; braiding; three dimensional/beading/implementation; tooth filing/fracturing/removal/tattooing; cartilage modification; amputation; genital modification; introduction of saline or other liquids.

2006A. Operation of Body Art Establishments

Unless otherwise ordered or approved by the Board, each body art establishment shall be constructed, operated and maintained to meet the following minimum requirements:

(A) Physical Plant

- (1) Walls, floors, ceilings, and procedure surfaces shall be smooth, durable, free of open holes or cracks, light-colored, washable, and in good repair. Walls, floors, and ceilings shall be maintained in a clean condition. All procedure surfaces, including client chairs/benches, shall be of such construction as to be easily cleaned and sanitized after each client.
- (2) Solid partitions or walls extending from floor to ceiling shall separate the establishment’s space from any other room used for human habitation, any food establishment or room where food is prepared, any hair salon, any retail sales, or any other such activity that may cause potential contamination of work surfaces.
- (3) The establishment shall take all measures necessary to ensure against the presence or breeding of insects, vermin, and rodents within the establishment.
- (4) Each operator area shall have a minimum of 45 square feet of floor space for each practitioner. Each establishment shall have an area that may be screened from public view for clients requesting privacy. Multiple body art stations shall be separated by dividers or a partition at a minimum.
- (5) The establishment shall be well ventilated and provided with an artificial light source equivalent to at least 20 foot candles 3 feet off the floor, except that at least 100 foot candles shall be provided at the level where the body art procedure is being performed where instruments and sharps are assembled and all cleaning areas.
- (6) All electrical outlets in operator areas and cleaning areas shall be equipped with approved ground fault (GFCI) protected receptacles.
- (7) A separate, readily accessible hand sink with hot and cold running water under pressure, preferably equipped with wrist- or foot-operated controls and supplied with liquid soap, and disposable paper towels stored in fixed dispensers shall be readily accessible within the establishment. Each operator area shall have a hand sink.
- (8) There shall be a sharps container in each operator area and each cleaning area.
- (9) There shall be a minimum of one toilet room containing a toilet and sink. The toilet room shall be provided with toilet paper, liquid hand soap and paper towels stored in a fixed dispenser. A body art establishment permanently

located within a retail shopping center, or similar setting housing multiple operations within one enclosed structure having shared entrance and exit points, shall not be required to provide a separate toilet room within such body art establishment if Board-approved toilet facilities are located in the retail shopping center within 300 feet of the body art establishment so as to be readily accessible to any client or practitioner.

- (10) The public water supply entering a body art establishment shall be protected by a testable, reduced pressure back flow preventor installed in accordance with 142 Code of Massachusetts Regulation 248, as amended from time to time.
- (11) At least one covered, foot operated waste receptacle shall be provided in each operator area and each toilet room. Receptacles in the operator area shall be emptied daily. Solid waste shall be stored in covered, leakproof, rodent-resistant containers and shall be removed from the premises at least weekly.
- (12) At least one janitorial sink shall be provided in each body art establishment for use in cleaning the establishment and proper disposal of non-contaminated liquid wastes in accordance with all applicable Federal, state and local laws. Said sink shall be of adequate size equipped with hot and cold running water under pressure and permit the cleaning of the establishment and any equipment used for cleaning.
- (13) All instruments and supplies shall be stored in clean, dry, and covered containers. Containers shall be kept in a secure area specifically dedicated to the storage of all instruments and supplies.
- (14) The establishment shall have a cleaning area. Every cleaning area shall have an area for the placement of an autoclave or other sterilization unit located or positioned a minimum of 36 inches from the required ultrasonic cleaning unit.
- (15) The establishment shall have a customer waiting area, exclusive and separate from any workstation, instrument storage area, cleaning area or any other area in the body art establishment used for body art activity.
- (16) No animals of any kind shall be allowed in a body art establishment except service animals used by persons with disabilities (e.g., Seeing Eye dogs). Fish aquariums shall be allowed in waiting rooms and nonprocedural areas.
- (17) Smoking, eating, or drinking is prohibited in the area where body art is performed, with the exception of non-alcoholic fluids being offered to a client during or after a body art procedure.

(B) Requirements for Single Use Items Including Inks, Dyes and Pigments

- (1) Single-use items shall not be used on more than one client for any reason. After use, all single-use sharps shall be immediately disposed of in approved sharps containers pursuant to 105 CMR 480.000.
- (2) All products applied to the skin, such as but not limited to body art stencils, applicators, gauze and razors, shall be single use and disposable.
- (3) Hollow bore needles or needles with cannula shall not be reused.

- (4) All inks, dyes, pigments, solid core needles, and equipment shall be specifically manufactured for performing body art procedures and shall be used according to manufacturer's instructions.
 - (5) Inks, dyes or pigments may be mixed and may only be diluted with water from an approved potable source. Immediately before a tattoo is applied, the quantity of the dye to be used shall be transferred from the dye bottle and placed into single-use paper cups or plastic cups. Upon completion of the tattoo, these single-use cups or caps and their contents shall be discarded.
- (C) Sanitation and Sterilization Measures and Procedures
- (1) All non-disposable instruments used for body art, including all reusable solid core needles, pins and stylets, shall be cleaned thoroughly after each use by scrubbing with an appropriate soap or disinfectant solution and hot water, (to remove blood and tissue residue), and shall be placed in an ultrasonic unit sold for cleaning purposes under approval of the U.S. Food and Drug Administration and operated in accordance with manufacturer's instructions.
 - (2) After being cleaned, all non-disposable instruments used for body art shall be packed individually in sterilizer packs and subsequently sterilized in a steam autoclave sold for medical sterilization purposes under approval of the U.S. Food and Drug Administration. All sterilizer packs shall contain either a sterilizer indicator or internal temperature indicator. Sterilizer packs must be dated with an expiration date not to exceed six (6) months.
 - (3) The autoclave shall be used, cleaned, and maintained according to manufacturer's instruction. A copy of the manufacturer's recommended procedures for the operation of the autoclave must be available for inspection by the Board. Autoclaves shall be located away from workstations or areas frequented by the public.
 - (4) Each holder of a permit to operate a body art establishment shall demonstrate that the autoclave used is capable of attaining sterilization by monthly spore destruction tests. These tests shall be verified through an independent laboratory. The permit shall not be issued or renewed until documentation of the autoclave's ability to destroy spores is received by the Board. These test records shall be retained by the operator for a period of three (3) years and made available to the Board upon request.
 - (5) All instruments used for body art procedures shall remain stored in sterile packages until just prior to the performance of a body art procedure. After sterilization, the instruments used in body art procedures shall be stored in a dry, clean cabinet or other tightly covered container reserved for the storage of such instruments.
 - (6) Sterile instruments may not be used if the package has been breached or after the expiration date without first repackaging and resterilizing.
 - (7) If the body art establishment uses only single-use, disposable instruments and products, and uses sterile supplies, an autoclave shall not be required.

- (8) When assembling instruments used for body art procedures, the operator shall wear disposable medical gloves and use medically recognized sterile techniques to ensure that the instruments and gloves are not contaminated.
- (9) Reusable cloth items shall be mechanically washed with detergent and mechanically dried after each use. The cloth items shall be stored in a dry, clean environment until used. Should such items become contaminated directly or indirectly with bodily fluids, the items shall be washed in accordance with standards applicable to hospitals and medical care facilities, at a temperature of 160°F or a temperature of 120°F with the use of chlorine disinfectant.

(D) Posting Requirements

The following shall be prominently displayed:

- (1) A Disclosure Statement, a model of which shall be available from the Board. A Disclosure Statement shall also be given to each client, advising him/her of the risks and possible consequences of body art procedures.
- (2) The name, address and phone number of the Wellfleet Board of Health.
- (3) An Emergency Plan, including:
 - (a) the event of an emergency;
 - (b) a telephone in good working order shall be easily available and accessible to all employees and clients during all hours of operation; and
 - (c) a sign at or adjacent to the telephone indicating the correct emergency telephone numbers.
- (4) An a plan for the purpose of contacting police, fire or emergency medical services in occupancy and use permit as issued by the local building official.
- (5) A current establishment permit.
- (6) Each practitioner's permit.

(E) Establishment Recordkeeping

The establishment shall maintain the following records in a secure place for a minimum of three (3) years, and such records shall be made available to the Board upon request:

- (1) Establishment information, which shall include:
 - (a) establishment name;
 - (b) hours of operation;
 - (c) owner's name and address;
 - (d) a complete description of all body art procedures performed;
 - (e) an inventory of all instruments and body jewelry, all sharps, and all inks used for any and all body art procedures, including names of manufacturers and serial or lot numbers, if applicable. Invoices or packing slips shall satisfy this requirement;
 - (f) Material Safety Data Sheet, when available, for each ink and dye used by the establishment;
 - (g) copies of waste hauler manifests
 - (h) copies of commercial biological monitoring tests
 - (i) a copy of these regulations.
- (2) Employee information, which shall include:

- (a) full legal names and exact duties;
- (b) date of birth;
- (c) home address;
- (d) home /work phone numbers;
- (e) identification photograph;
- (f) dates of employment;
- (g) Hepatitis B vaccination status or declination notification;
- (h) Training records

(3) Client Information, which shall include:

- (a) name;
- (b) valid photo identification and date of birth;
- (c) address of the client;
- (d) date of the procedure;
- (e) name of the practitioner who performed the procedure(s);
- (f) description of procedure(s) performed and the location on the body;
- (g) a signed consent form as specified by 7(D)(2); and,
- (h) if the client is a person under the age of 18, proof of parental or guardian identification, presence and consent including a copy of the photographic identification of the parent or guardian.

Client information shall be kept confidential at all times.

(4) Exposure Control Plan

Each establishment shall create, update, and comply with an Exposure Control Plan. The Plan shall be submitted to the Board for review so as to meet all of the requirements of OSHA regulations, to include, but not limited to, 29 Code of Federal Regulation 1910.1030 OSHA Bloodborne Pathogens Standards et seq, as amended from time to time. A copy of the Plan shall be maintained at the Body Art Establishment at all times and shall be made available to the Board upon request.

(F) No person shall establish or operate a mobile or temporary Body Art Establishment.

2007A. Standards of Practice

Practitioners are required to comply with the following minimum health standards:

- (A) A practitioner shall perform all body art procedures in accordance with Universal Precautions set forth by the U.S Centers for Disease Control and Prevention.
- (B) A practitioner shall refuse service to any person who may be under the influence of alcohol or drugs.
- (C) Practitioners who use ear-piercing systems must conform to the manufacturers directions for use, and to applicable U.S. Food and Drug Administration requirements. No practitioner shall use an ear piercing system on any part of the client's body other than the lobe of the ear.

- (D) Health History and Client Informed Consent. Prior to performing a body art procedure on a client, the practitioner shall:
- (1) Inform the client, verbally and in writing that the following health conditions may increase health risks associated with receiving a body art procedure:
 - (a) history of diabetes;
 - (b) history of hemophilia (bleeding);
 - (c) history of skin diseases, skin lesions, or skin sensitivities to soaps, disinfectants etc.;
 - (d) history of allergies or adverse reactions to pigments, dyes, or other sensitivities;
 - (e) history of epilepsy, seizures, fainting, or narcolepsy;
 - (f) use of medications such as anticoagulants, which thin the blood and/or interfere with blood clotting; and
 - (g) any other conditions such as hepatitis or HIV.
 - (2) Require that the client sign a form confirming that the above information was provided, that the client does not have a condition that prevents them from receiving body art, that the client consents to the performance of the body art procedure and that the client has been given the aftercare instructions as required by section 7(K).
- (E) A practitioner shall maintain the highest degree of personal cleanliness, conform to best standard hygienic practices, and wear clean clothes when performing body art procedures. Before performing body art procedures, the practitioner must thoroughly wash their hands in hot running water with liquid soap, then rinse hands and dry with disposable paper towels. This shall be done as often as necessary to remove contaminants.
- (F) In performing body art procedures, a practitioner shall wear disposable single-use gloves. Gloves shall be changed if they become pierced, torn, or otherwise contaminated by contact with any unclean surfaces or objects or by contact with a third person. The gloves shall be discarded, at a minimum, after the completion of each procedure on an individual client, and hands shall be washed in accordance with section (E) before the next set of gloves is put on. Under no circumstances shall a single pair of gloves be used on more than one person. The use of disposable single-use gloves does not preclude or substitute for handwashing procedures as part of a good personal hygiene program.
- (G) The skin of the practitioner shall be free of rash or infection. No practitioner affected with boils, infected wounds, open sores, abrasions, weeping dermatological lesions or acute respiratory infection shall work in any area of a body art establishment in any capacity in which there is a likelihood that that person could contaminate body art equipment, supplies, or working surfaces with body substances or pathogenic organisms.
- (H) Any item or instrument used for body art that is contaminated during the procedure shall be discarded and replaced immediately with a new disposable item or a new sterilized instrument or item before the procedure resumes.
- (I) Preparation and care of a client's skin area must comply with the following:
- (1) Any skin or mucosa surface to receive a body art procedure shall be free of rash or any visible infection.

- (2) Before a body art procedure is performed, the immediate skin area and the areas of skin surrounding where body art procedure is to be placed shall be washed with soap and water or an approved surgical skin preparation. If shaving is necessary, single-use disposable razors or safety razors with single-service blades shall be used. Blades shall be discarded after each use, and reusable holders shall be cleaned and autoclaved after use. Following shaving, the skin and surrounding area shall be washed with soap and water. The washing pad shall be discarded after a single use.
 - (3) In the event of bleeding, all products used to stop the bleeding or to absorb blood shall be single use, and discarded immediately after use in appropriate covered containers, and disposed of in accordance with 105 CMR 480.000.
- (J) Petroleum jellies, soaps, and other products used in the application of stencils shall be dispensed and applied on the area to receive a body art procedure with sterile gauze or other sterile applicator to prevent contamination of the original container and its contents. The applicator or gauze shall be used once and then discarded.
- (K) The practitioner shall provide each client with verbal and written instructions on the aftercare of the body art site. The written instructions shall advise the client:
- (1) on the proper cleansing of the area which received the body art;
 - (2) to consult a health care provider for:
 - (a) unexpected redness, tenderness or swelling at the site of the body art procedure;
 - (b) any rash;
 - (c) unexpected drainage at or from the site of the body art procedure; or
 - (d) a fever within 24 hours of the body art procedure; and
 - (3) of the address, and phone number of the establishment.
- A copy shall be provided to the client. A model set of aftercare instructions shall be made available by the Board.
- (L) Contaminated waste shall be stored, treated and disposed in accordance with 105 CMR 480.000: Storage and Disposal of Infectious or Physically Dangerous Medical or Biological Waster, State Sanitary Code, Chapter VIII.

2008A. Injury and/or Complication Reports

A written report of any injury, infection complication or disease as a result of a body art procedure, or complaint of injury, infection complication or disease, shall be forwarded by the operator to the Board which issued the permit, with a copy to the injured client within five working days of its occurrence or knowledge thereof. The report shall include:

- (A) the name of the affected client;
- (B) the name and location of the body art establishment involved;
- (C) the nature of the injury, infection complication or disease;
- (D) the name and address of the affected client's health care provider, if any;
- (E) any other information considered relevant to the situation.

2009A. Complaints

- (A) The Board shall investigate complaints received about an establishment or practitioner's practices or acts, which may violate any provision of the Board's regulations.
- (B) If the Board finds that an investigation is not required because the alleged act or practice is not in violation of the Board's regulations, then the Board shall notify the complainant of this finding and the reasons on which it is based.
- (C) If the Board finds that an investigation is required, because the alleged act or practice may be in violation of the Board's regulations, the Board shall investigate and if a finding is made that the act or practice is in violation of the Board's regulations, then the Board shall apply whatever enforcement action is appropriate to remedy the situation and shall notify the complainant of its action in this manner.

2010A. Application for Body Art Establishment Permit

- (A) No person may operate a body art establishment except with a valid permit from the Board.
- (B) Applications for a permit shall be made on forms prescribed by and available from the Board. An applicant shall submit all information required by the form and accompanying instructions. The term "application" as used herein shall include the original and renewal applications.
- (C) An establishment permit shall be valid from the date of issuance and shall expire on December 31st of the year in which it was issued.
- (D) The Board shall require that the applicant provide, at a minimum, the following information in order to be issued an establishment permit:
 - (1) Name, address, and telephone number of:
 - (a) the body art establishment;
 - (b) the operator of the establishment; and
 - (c) the body art practitioner(s) working at the establishment;
 - (2) The manufacturer, model number, model year, and serial number, where applicable, of the autoclave used in the establishment;
 - (3) A signed and dated acknowledgment that the applicant has received, read and understood the requirements of the Board's body art regulations;
 - (4) A drawing of the floor plan of the proposed establishment to scale for a plan review by the Board, as part of the permit application process; and,
 - (5) Exposure Report Plan
 - (6) Such additional information as the Board may reasonably require.
- (E) The annual fee for the Body Art Establishment Permit shall be \$600.00.
- (F) A permit for a body art establishment shall not be transferable from one place or person to another.

2011A. Application for Body Art Practitioner Permit

- (A) No person shall practice body art or perform any body art procedure without first obtaining a practitioner permit from the Board. The annual fee for a practitioner permit shall be \$400.00.
- (B) A practitioner shall be a minimum of 18 years of age.

- (C) A practitioner permit shall be valid from the date of issuance and shall expire on December 31st of the year in which it was issued.
- (D) Application for a practitioner permit shall include:
- (1) name;
 - (2) date of birth;
 - (3) residence address;
 - (4) mailing address;
 - (5) phone number;
 - (6) place(s) of employment as a practitioner; and
 - (7) training and/or experience as set out in (E) below.
- (E) Practitioner Training and Experience
- (1) In reviewing an application for a practitioner permit, the Board may consider experience, training and/or certification acquired in other states that regulate body art.
 - (2) Training for all practitioners shall be approved by the Board and, at a minimum, shall include the following:
 - (a) bloodborne pathogen training program (or equivalent) which includes infectious disease control; waste disposal; hand washing techniques; sterilization equipment operation and methods; and sanitization, disinfection and sterilization methods and techniques; and
 - (b) Current certification in First Aid and cardiopulmonary resuscitation (CPR).

Examples of courses approved by the Board include "Preventing Disease Transmission" (American Red Cross) and "Bloodborne Pathogen Training" (U.S. OSHA). Training/courses provided by professional body art organizations or associations or by equipment manufacturers may also be submitted to the Board for approval.
 - (3) All applicants shall provide documentation, acceptable to the Board, that s/he completed a course on anatomy and physiology with a grade of C or better at a college accredited by the New England Association of Schools and Colleges, or comparable accrediting entity. This course must include instruction on the system of the integumentary system (skin).
 - (4) The applicant for all practitioners shall submit evidence satisfactory to the Board of at least two years actual experience in the practice of performing body art activities of the kind for which the applicant seeks a body art practitioner permit to perform, whether such experience was obtained within or outside of the Commonwealth.
- (F) A practitioner's permit shall be conditioned upon continued compliance with all applicable provisions of these rules and regulations.
- (G) The Board may consider the application for student/apprentice practitioner provided the applicant must perform under the direct supervision of a permitted practitioner.

- (A) The Board may suspend a permit, deny a permit, revoke a permit or refuse to renew a permit on the following grounds, each of which, in and of itself, shall constitute full and adequate grounds for suspension, denial, revocation or refusal to renew:
- (1) any actions which would indicate that the health or safety of the public would be at risk;
 - (2) fraud, deceit or misrepresentation in obtaining a permit, or its renewal;
 - (3) criminal conduct which the Board determines to be of such a nature as to render the establishment, practitioner or applicant unfit to practice body art as evidenced by criminal proceedings resulting in a conviction, guilty plea, or plea of *nolo contendere* or an admission of sufficient facts;
 - (a) any present or past violation of the Board's regulations governing the practice of body art;
 - (b) practicing body art while the ability to practice is impaired by alcohol, drugs, physical disability or mental instability;
 - (c) being habitually drunk or being dependent on, or a habitual user of narcotics, barbiturates, amphetamines, hallucinogens, or other drugs having similar effects;
 - (d) knowingly permitting, aiding or abetting an unauthorized person to perform activities requiring a permit;
 - (e) continuing to practice while his/her permit is lapsed, suspended, or revoked;
 - and
 - (f) having been disciplined in another jurisdiction in any way by the proper permitting authority for reasons substantially the same as those set forth in the Board's regulations.
 - (g) other just and sufficient cause which the Board may determine would render the establishment, practitioner or applicant unfit to practice body art.
- (B) The Board shall notify an applicant, establishment or practitioner in writing of any violation of the Board's regulations, for which the Board intends to deny, revoke, or refuse to renew a permit. The applicant, establishment or practitioner shall have seven (7) days after receipt of such written notice in which to comply with the Board's regulations. The Board may deny, revoke or refuse to renew a permit, if the applicant, establishment or practitioner fails to comply after said seven (7) days subject to the procedure outlined in Section 14.
- (C) Applicants denied a permit may reapply at any time after denial.

2013A. Grounds for Suspension of Permit

The Board may summarily suspend a permit pending a final hearing on the merits on the question of revocation if, based on the evidence before it, the Board determines that an establishment and/or a practitioner is an immediate and serious threat to the public health, safety or welfare. The suspension of a permit shall take effect immediately upon written notice of such suspension by the Board.

2014A. Procedure for Hearings

The owner of the establishment or practitioner shall be given written notice of the Board's intent to hold a hearing for the purpose of suspension, revocation, denial or refusal to renew a permit.

This written notice shall be served through a certified letter sent return receipt requested or by constable. The notice shall include the date, time and place of the hearing and the owner of the establishment or practitioner's right to be heard. The Board shall hold the hearing no later than 21 days from the date the written notice is received.

In the case of a suspension of a permit as noted in Section 2012A, a hearing shall be scheduled no later than 21 days from the date of the suspension.

2015A. Severability

If any provision contained in the model regulations is deemed invalid for any reason, it shall be severed and shall not affect the validity of the remaining provisions.

2016A. Violations, Penalties and Enforcement

Non-Criminal Disposition -Whoever violates any provision of these rules and regulations may be penalized by a non-criminal method in the District Court pursuant to the provisions of MGL Chapter 40ss 21D. For the purposes of this regulation the following fine schedule will be imposed:

- First offense – written warning
- Second offense - \$50.00
- Third offense - \$100.00
- Fourth and subsequent offenses - \$300.00

Each day on which a violation exists shall be deemed to be a separate offense. The third offense at a single facility shall result in a hearing before the Board of Health to suspend or withdraw a body art license if appropriate or a determination to file a criminal complaint.

Criminal Complaint – as provided in MGL Chapter 111 § 31 – Whoever violates any provision of these rules and regulations may be penalized by indictment or complaint brought in District Court. Except as otherwise provided by law, the fine shall be \$1,000.00 for each offense.

2017A. Variances

Variances from this regulation may be granted by the Board of Health after a hearing at which the applicant establishes the following:

- (a) Enforcement thereof would do manifest injustice; and
- (b) A variance contemplated from these regulations will not in the opinion of the Board of Health adversely affect the purpose and intent of this regulation.

3000 MISCELLANEOUS REGULATIONS

3001 All commercial establishments must have automatic pilots on their gas appliances, with 100% shutoffs. Any appliance found unsafe will be subject to removal. This applies to all preexisting appliances.

4000: Tobacco Control (Effective January 1, 2018)

4001: Statement of Purpose:

Whereas there exists conclusive evidence that tobacco smoking causes cancer, respiratory and cardiac diseases, negative birth outcomes, irritations to the eyes, nose and throat¹;

Whereas the U.S. Department of Health and Human Services has concluded that nicotine is as addictive as cocaine or heroin² and the Surgeon General found that nicotine exposure during adolescence, a critical window for brain development, may have lasting adverse consequences for brain development,³ and that it is addiction to nicotine that keeps youth smoking past adolescence.⁴

Whereas a Federal District Court found that Phillip Morris, RJ Reynolds and other leading cigarette manufacturers “spent billions of dollars every year on their marketing activities in order to encourage young people to try and then continue purchasing their cigarette products in order to provide the replacement smokers they need to survive” and that these companies were likely to continue targeting underage smokers⁵;

Whereas more than 80 percent of all adult smokers begin smoking before the age of 18, more than 90 percent do so before leaving their teens, and more than 3.5 million middle and high school students smoke;⁶

Whereas 18.1 percent of current smokers aged <18 years reported that they *usually* directly purchased their cigarettes from stores (i.e. convenience store, supermarket, or discount store) or gas stations, and among 11th grade males this rate was nearly 30 percent ;⁷

Whereas the Institute of Medicine (IOM) concludes that raising the minimum age of legal access to tobacco products to 21 will likely reduce tobacco initiation, particularly among adolescents 15 – 17, which would improve health across the lifespan and save lives⁸.

¹ Center for Disease Control and Prevention, (CDC) (2012), *Health Effects of Cigarette Smoking Fact Sheet*. Retrieved from: http://www.cdc.gov/tobacco/data_statistics/fact_sheets/health_effects/effects_cig_smoking/index.htm.

² CDC (2010), *How Tobacco Smoke Causes Disease: The Biology and Behavioral Basis for Smoking-Attributable Disease*. Retrieved from: http://www.cdc.gov/tobacco/data_statistics/sgr/2010/.

³ U.S. Department of Health and Human Services. 2014. *The Health Consequences of Smoking – 50 Years of Progress: A Report of the Surgeon General*. Atlanta: U.S. National Center for Chronic Disease Prevention and Health Promotion, Office on Smoking and Health, p. 122. Retrieved from: <http://www.surgeongeneral.gov/library/reports/50-years-of-progress/full-report.pdf>.

⁴ *Id.* at Executive Summary p. 13. Retrieved from: <http://www.surgeongeneral.gov/library/reports/50-years-of-progress/exec-summary.pdf>

⁵ *United States v. Phillip Morris, Inc., RJ Reynolds Tobacco Co., et al.*, 449 F.Supp.2d 1 (D.D.C. 2006) at Par. 3301 and Pp. 1605-07.

⁶ SAMHSA, Calculated based on data in 2011 National Survey on Drug Use and Health and U. S. Department of Health and Human services (HHA).

⁷ CDC (2013) Youth Risk Behavior, Surveillance Summaries (MMWR 2014: 63 (No SS-04)). Retrieved from: www.cdc.gov.

⁸ IOM (Institute of Medicine) 2015. *Public Health Implications of Raising the Minimum Age of Legal Access to Tobacco Products*. Washington DC: The National Academies Press, 2015.

Whereas cigars and cigarillos, can be sold in a single “dose;” enjoy a relatively low tax as compared to cigarettes; are available in fruit, candy and alcohol flavors; and are popular among youth⁹;

Whereas research shows that increased cigar prices significantly decreased the probability of male adolescent cigar use and a 10% increase in cigar prices would reduce use by 3.4%¹⁰;

Whereas 59% of high school smokers in Massachusetts have tried flavor cigarettes or flavored cigars and 25.6% of them are current flavored tobacco product users; 95.1 % of 12 – 17 year olds who smoked cigars reported smoking cigar brands that were flavored;¹¹

Whereas the Surgeon General found that exposure to tobacco marketing in stores and price discounting increase youth smoking;¹²

Whereas the federal Family Smoking Prevention and Tobacco Control Act (FSPTCA), enacted in 2009, prohibited candy- and fruit-flavored cigarettes,¹³ largely because these flavored products were marketed to youth and young adults,¹⁴ and younger smokers were more likely to have tried these products than older smokers¹⁵, neither federal nor Massachusetts laws restrict sales of flavored non-cigarette tobacco products, such as cigars, cigarillos, smokeless tobacco, hookah tobacco, and electronic devices and the nicotine solutions used in these devices;

⁹ CDC (2009), *Youth Risk Behavior, Surveillance Summaries* (MMWR 2010: 59, 12, note 5). Retrieved from: <http://www.cdc.gov/mmwr/pdf/ss/ss5905.pdf>.

¹⁰ Ringel, J., Wasserman, J., & Andreyeva, T. (2005) *Effects of Public Policy on Adolescents' Cigar Use: Evidence from the National Youth Tobacco Survey*. *American Journal of Public Health*, 95(6), 995-998, doi: 10.2105/AJPH.2003.030411 and cited in *Cigar, Cigarillo and Little Cigar Use among Canadian Youth: Are We Underestimating the Magnitude of this Problem?*, *J. Prim. P.* 2011, Aug: 32(3-4):161-70. Retrieved from: www.ncbi.nlm.nih.gov/pubmed/21809109.

¹¹ Massachusetts Department of Public Health, 2015 Massachusetts Youth Health Survey (MYHS); Delneve CD et al., *Tob Control*, March 2014: Preference for flavored cigar brands among youth, young adults and adults in the USA.

¹² U.S. Department of Health and Human Services. 2012. *Preventing Tobacco Use Among Youth and Young Adults: A Report of the Surgeon General*. Atlanta: U.S. National Center for Chronic Disease Prevention and Health Promotion, Office on Smoking and Health, p. 508-530, www.surgeongeneral.gov/library/reports/preventing-youth-tobacco-use/full-report.pdf.

¹³ 21 U.S.C. § 387g.

¹⁴ Carpenter CM, Wayne GF, Pauly JL, et al. 2005. “New Cigarette Brands with Flavors that Appeal to Youth: Tobacco Marketing Strategies.” *Health Affairs*. 24(6): 1601–1610; Lewis M and Wackowski O. 2006. “Dealing with an Innovative Industry: A Look at Flavored Cigarettes Promoted by Mainstream Brands.” *American Journal of Public Health*. 96(2): 244–251; Connolly GN. 2004. “Sweet and Spicy Flavours: New Brands for Minorities and Youth.” *Tobacco Control*. 13(3): 211–212; U.S. Department of Health and Human Services. 2012. *Preventing Tobacco Use Among Youth and Young Adults: A Report of the Surgeon General*. Atlanta: U.S. National Center for Chronic Disease Prevention and Health Promotion, Office on Smoking and Health, p. 537, www.surgeongeneral.gov/library/reports/preventing-youth-tobacco-use/full-report.pdf.

¹⁵ U.S. Department of Health and Human Services. 2012. *Preventing Tobacco Use Among Youth and Young Adults: A Report of the Surgeon General*. Atlanta: U.S. National Center for Chronic Disease Prevention and Health Promotion, Office on Smoking and Health, p. 539, www.surgeongeneral.gov/library/reports/preventing-youth-tobacco-use/full-report.pdf.

Whereas the U.S. Food and Drug Administration and the U.S. Surgeon General have stated that flavored tobacco products are considered to be “starter” products that help establish smoking habits that can lead to long-term addiction;¹⁶

Whereas the U.S. Surgeon General recognized in his 2014 report that a complementary strategy to assist in eradicating tobacco related death and disease is for local governments to ban categories of products from retail sale;¹⁷

Whereas the U.S. Centers for Disease Control and Prevention has reported that the current use of electronic cigarettes, a product sold in dozens of flavors that appeal to youth, among middle and high school students tripled from 2013 to 2014;¹⁸

Whereas 5.8% of Massachusetts youth currently use e-cigarettes and 15.9% have tried them;¹⁹

Whereas the Massachusetts Department of Environmental Protection has classified liquid nicotine in any amount as an “acutely hazardous waste”;²⁰

Whereas in a lab analysis conducted by the FDA, electronic cigarette cartridges that were labeled as containing no nicotine actually had low levels of nicotine present in all cartridges tested, except for one²¹;

Whereas according to the CDC’s youth risk behavior surveillance system, the percentage of high school students in Massachusetts who reported the use of cigars within the past 30 days is 10.8% in 2013;²²

Whereas data from the National Youth Tobacco Survey indicate that more than two-fifths of U.S. middle and high school smokers report using flavored little cigars or flavored cigarettes;²³

Whereas the sale of tobacco products is incompatible with the mission of health care institutions because these products are detrimental to the public health and their presence in health care institutions undermine efforts to educate patients on the safe and effective use of medication,

¹⁶ Food and Drug Administration. 2011. *Fact Sheet: Flavored Tobacco Products*, www.fda.gov/downloads/TobaccoProducts/ProtectingKidsfromTobacco/FlavoredTobacco/UCM183214.pdf; U.S. Department of Health and Human Services. 2012. *Preventing Tobacco Use Among Youth and Young Adults: A Report of the Surgeon General*. Atlanta: U.S. National Center for Chronic Disease Prevention and Health Promotion, Office on Smoking and Health, p. 539, www.surgeongeneral.gov/library/reports/preventing-youth-tobacco-use/full-report.pdf.

¹⁷ See fn. 3 at p. 85.

¹⁸ Centers for Disease Control & Prevention. 2015. “Tobacco Use Among Middle and High School Students — United States, 2011–2014,” *Morbidity and Mortality Weekly Report (MMWR)* 64(14): 381–385;

¹⁹ Massachusetts Department of Public Health, 2015 Massachusetts Youth Health Survey (MYHS)

²⁰ 310 CMR 30.136

²¹ Food and Drug Administration, *Summary of Results: Laboratory Analysis of Electronic Cigarettes Conducted by FDA*, available at: <http://www.fda.gov/newsevents/publichealthfocus/ucm173146.htm>.

²² See fn. 7.

²³ King BA, Tynan MA, Dube SR, et al. 2013. “Flavored-Little-Cigar and Flavored-Cigarette Use Among U.S. Middle and High School Students.” *Journal of Adolescent Health*. [Article in press], www.jahonline.org/article/S1054-139X%2813%2900415-1/abstract.

including cessation medication;

Whereas educational institutions sell tobacco products to a younger population, who is particularly at risk for becoming smokers and such sale of tobacco products is incompatible with the mission of educational institutions that educate a younger population about social, environmental and health risks and harms;

Whereas the Massachusetts Supreme Judicial Court has held that “. . . [t]he right to engage in business must yield to the paramount right of government to protect the public health by any rational means”²⁴.

Now, therefore it is the intention of the Wellfleet Board of Health to regulate the sale of tobacco products.

4002 Authority:

This regulation is promulgated pursuant to the authority granted to the Wellfleet Board of Health by Massachusetts General Laws Chapter 111, Section 31 which states "Boards of health may make reasonable health regulations".

4003 Definitions:

For the purpose of this regulation, the following words shall have the following meanings:

Adult-only retail tobacco store: An establishment that is not required to possess a retail food permit whose primary purpose is to sell or offer for sale but not for resale, tobacco products and tobacco paraphernalia, in which the sale of other products is merely incidental, and in which the entry of persons under the minimum legal sales age is prohibited at all times, and maintains a valid permit for the retail sale of tobacco products as required to be issued by the Wellfleet Board of Health.

Blunt Wrap: Any tobacco product manufactured or packaged as a wrap or as a hollow tube made wholly or in part from tobacco that is designed or intended to be filled by the consumer with loose tobacco or other fillers regardless of any content.

Business Agent: An individual who has been designated by the owner or operator of any establishment to be the manager or otherwise in charge of said establishment.

Characterizing flavor: A distinguishable taste or aroma, other than the taste or aroma of tobacco, menthol, mint or wintergreen, imparted or detectable either prior to or during consumption of a tobacco product or component part thereof, including, but not limited to, tastes or aromas relating to any fruit, chocolate, vanilla, honey, candy, cocoa, dessert, alcoholic beverage, herb or spice; provided, however, that no tobacco product shall be determined to have a characterizing flavor solely because of the provision of ingredient information or the use of additives or flavorings that do not contribute to the distinguishable taste or aroma of the product.

²⁴ Druzik et al v. Board of Health of Haverhill, 324 Mass.129 (1949).

Cigar: Any roll of tobacco that is wrapped in leaf tobacco or in any substance containing tobacco with or without a tip or mouthpiece not otherwise defined as a cigarette under Massachusetts General Law, Chapter 64C, Section 1, Paragraph 1.

Component part: Any element of a tobacco product, including, but not limited to, the tobacco, filter and paper, but not including any constituent.

Constituent: Any ingredient, substance, chemical or compound, other than tobacco, water or reconstituted tobacco sheet, that is added by the manufacturer to a tobacco product during the processing, manufacturing or packaging of the tobacco product. Such term shall include a smoke constituent.

Coupon: Any card, paper, note, form, statement, ticket or other issue distributed for commercial or promotional purposes to be later surrendered by the bearer so as to receive an article, service or accommodation without charge or at a discount price.

Distinguishable: Perceivable by either the sense of smell or taste.

Educational Institution: Any public or private college, school, professional school, scientific or technical institution, university or other institution furnishing a program of higher education.

Employee: Any individual who performs services for an employer.

Employer: Any individual, partnership, association, corporation, trust or other organized group of individuals that uses the services of one (1) or more employees.

Flavored tobacco product: Any tobacco product or component part thereof that contains a constituent that has or produces a characterizing flavor. A public statement, claim or indicia made or disseminated by the manufacturer of a tobacco product, or by any person authorized or permitted by the manufacturer to make or disseminate public statements concerning such tobacco product, that such tobacco product has or produces a characterizing flavor shall constitute presumptive evidence that the tobacco product is a flavored tobacco product.

Health Care Institution: An individual, partnership, association, corporation or trust or any person or group of persons that provides health care services and employs health care providers licensed, or subject to licensing, by the Massachusetts Department of Public Health under M.G.L. c. 112 or a retail establishment that provides pharmaceutical goods and services and is subject to the provisions of 247 CMR 6.00. Health care institutions include, but are not limited to, hospitals, clinics, health centers, pharmacies, drug stores, doctor offices, optician/optometrist offices and dentist offices.

Liquid Nicotine Container: A bottle or other vessel which contains nicotine in liquid or gel form, whether or not combined with another substance or substances, for use in a tobacco product, as defined herein. The term does not include a container containing nicotine in a cartridge that is sold, marketed, or intended for use in a tobacco product, as defined herein, if the cartridge is prefilled and sealed by the manufacturer and not intended to be open by the consumer or retailer.

Listed or non-discounted price: The higher of the price listed for a tobacco product on its package or the price listed on any related shelving, posting, advertising or display at the place where the tobacco product is sold or offered for sale plus all applicable taxes if such taxes are not included in the state price, and before the application of any discounts or coupons.

Minimum Legal Sales Age (MLSA): The age an individual must be before that individual can be sold a tobacco product in the municipality.

Non-Residential Roll-Your-Own (RYO) Machine: A mechanical device made available for use (including to an individual who produces cigars, cigarettes, smokeless tobacco, pipe tobacco, or roll-your-own tobacco solely for the individual's own personal consumption or use) that is capable of making cigarettes, cigars or other tobacco products. RYO machines located in private homes used for solely personal consumption are not Non-Residential RYO machines.

Permit Holder: Any person engaged in the sale or distribution of tobacco products who applies for and receives a tobacco product sales permit or any person who is required to apply for a Tobacco Product Sales Permit pursuant to these regulations, or his or her business agent.

Person: Any individual, firm, partnership, association, corporation, company or organization of any kind, including but not limited to, an owner, operator, manager, proprietor or person in charge of any establishment, business or retail store.

Self-Service Display: Any display from which customers may select a tobacco product, as defined herein, without assistance from an employee or store personnel.

Schools: Public or private elementary or secondary schools.

Smoke Constituent: Any chemical or chemical compound in mainstream or sidestream tobacco smoke that either transfers from any component of the tobacco product to the smoke or that is formed by the combustion or heating of tobacco, additives or other component of the tobacco product.

Smoking Bar: An establishment that primarily is engaged in the retail sale of tobacco products for consumption by customers on the premises and is required by Mass. General Law Ch. 270, §22 to maintain a valid permit to operate a smoking bar issued by the Massachusetts Department of Revenue. "Smoking bar" shall include, but not be limited to, those establishments that are commonly known as "cigar bars" and "hookah bars".

Tobacco Product: Any product containing, made, or derived from tobacco or nicotine that is intended for human consumption, whether smoked, chewed, absorbed, dissolved, inhaled, snorted, sniffed, or ingested by any other means, including, but not limited to: cigarettes, cigars, little cigars, chewing tobacco, pipe tobacco, snuff; or electronic cigarettes, electronic cigars, electronic pipes, electronic hookah, liquid nicotine, "e-liquids" or other similar products, regardless of nicotine content, that rely on vaporization or aerosolization. "Tobacco product" includes any component or part of a tobacco product. "Tobacco product" does not include any product that has been approved by the United States Food and Drug Administration either as a tobacco use cessation product or for other medical purposes and which is being marketed and sold or prescribed solely for the approved purpose.

Vending Machine: Any automated or mechanical self-service device, which upon insertion of money, tokens or any other form of payment, dispenses or makes cigarettes or any other tobacco products, as defined herein.

4004 Tobacco Sales to Persons Under the Minimum Legal Sales Age Prohibited:

1. No person shall sell tobacco products or permit tobacco products, as defined herein, to be sold to a person under the minimum legal sales age; or not being the individual's parent or legal guardian, give tobacco products, as defined herein, to a person under the minimum legal sales age. The minimum legal sales age in Wellfleet is twenty-one (21).

2. Required Signage:

- a. In conformance with and in addition to Massachusetts General Law, Chapter 270, Section 7, a copy of Massachusetts General Laws, Chapter 270, Section 6, shall be posted conspicuously by the owner or other person in charge thereof in the shop or other place used to sell tobacco products at retail. The notice shall be provided by the Massachusetts Department of Public Health and made available from the Wellfleet Board of Health. The notice shall be at least 48 square inches and shall be posted conspicuously by the permit holder in the retail establishment or other place in such a manner so that it may be readily seen by a person standing at or approaching the cash register. The notice shall directly face the purchaser and shall not be obstructed from view or placed at a height of less than 4 feet or greater than 9 feet from the floor. The owner or other person in charge of a shop or other place used to sell tobacco products at retail shall conspicuously post any additional signs required by the Massachusetts Department of Public Health. The owner or other person in charge of a shop or other place used to sell hand rolled cigars must display a warning about cigar consumption in a sign at least 50 square inches pursuant to 940 CMR 22.06 (2) (e).
- b. The owner or other person in charge of a shop or other place used to sell tobacco products, as defined herein, at retail shall conspicuously post signage provided by the Wellfleet Board of Health that discloses current referral information about smoking cessation.
- c. The owner or other person in charge of a shop or other place used to sell tobacco products that rely on vaporization or aerosolization, as defined herein as “tobacco products”, at retail shall conspicuously post a sign stating that “The sale of tobacco products, including e-cigarettes, to someone under the minimum legal sales age of 21 years is prohibited.” The notice shall be no smaller than 8.5 inches by 11 inches and shall be posted conspicuously in the retail establishment or other place in such a manner so that it may be readily seen by a person standing at or approaching the cash register. The notice shall directly face the purchaser and shall not be obstructed from view or placed at a height of less than four (4) feet or greater than nine (9) feet from the floor.

3. Identification: Each person selling or distributing tobacco products, as defined herein, shall verify the age of the purchaser by means of a valid government-issued photographic identification containing the bearer's date of birth that the purchaser is 21 years old or older. Verification is required for any person under the age of 27.

4. All retail sales of tobacco products, as defined herein, must be face-to-face between the seller and the buyer and occur at the permitted location.

4005 Tobacco Product Sales Permit:

1. No person shall sell or otherwise distribute tobacco products, as defined herein, within the Town of Wellfleet without first obtaining a Tobacco Product Sales Permit issued annually by the Wellfleet Board of Health. Only owners of establishments with a permanent, non-mobile location in Wellfleet are eligible to apply for a permit and sell tobacco products, as defined herein, at the specified location in Wellfleet.

2. As part of the Tobacco Product Sales Permit application process, the applicant will be provided with the Wellfleet regulation. Each applicant is required to sign a statement declaring that the applicant has read said regulation and that the applicant is responsible for instructing any and all employees who will be responsible for tobacco product sales regarding federal, state and local laws regarding the sale of tobacco and this regulation.

3. Each applicant who sells tobacco products is required to provide proof of a current Tobacco Retailer License issued by the Massachusetts Department of Revenue, when required by state law, before a Tobacco Product Sales Permit can be issued.

4. A separate permit, displayed conspicuously, is required for each retail establishment selling tobacco products, as defined herein. The fee for which shall be determined by the Wellfleet Board of Health annually.

5. A Tobacco Product Sales Permit is non-transferable. A new owner of an establishment that sells tobacco products, as defined herein, must apply for a new permit. No new permit will be issued unless and until all outstanding penalties incurred by the previous permit holder are satisfied in full.

6. Issuance of a Tobacco Product Sales Permit shall be conditioned on an applicant's consent to unannounced, periodic inspections of his/her retail establishment to ensure compliance with this regulation.

7. A Tobacco Product Sales Permit will not be renewed if the permit holder has failed to pay all fines issued and the time period to appeal the fines has expired and/or the permit holder has not satisfied any outstanding permit suspensions.

8. A Tobacco Product Sales Permit shall not be issued to any new applicant for a retail location within 500 feet of a public or private elementary or secondary school as measured by a straight line from the nearest point of the property line of the school to the nearest point of the property line of the site of the applicant's business premises.

9. Applicants who purchase an existing business that holds a valid Tobacco Product Sales Permit at the time of the sale of said business must apply within sixty (60) days of such sale for the permit held by the Seller if the Buyer intends to sell tobacco products, as defined herein.

4006 Cigar Sales Regulated:

1. No person shall sell or distribute or cause to be sold or distributed a single cigar.

2. No person shall sell or distribute or cause to be sold or distributed any original factory-wrapped package of two or more cigars, unless such package is priced for retail sale at \$5.00 or more.

3. This Section shall not apply to:

- a. The sale or distribution of any single cigar having a retail price of two dollars and fifty cents (\$2.50) or more.
- b. A person or entity engaged in the business of selling or distributing cigars for commercial purposes to another person or entity engaged in the business of selling or distributing cigars for commercial purposes with the intent to sell or distribute outside the boundaries of Wellfleet.

4. The Wellfleet Board of Health may adjust from time to time the amounts specified in this Section to reflect changes in the applicable Consumer Price Index by amendment of this regulation.

4007 Sale of Flavored Tobacco Products Prohibited:

No person shall sell or distribute or cause to be sold or distributed any flavored tobacco product, except in smoking bars and adult-only retail tobacco stores.

4008 Prohibition of the Sale of Blunt Wraps:

No person or entity shall sell or distribute blunt wraps in Wellfleet.

4009 Free Distribution and Coupon Redemption:

No person shall:

1. Distribute or cause to be distributed, any free samples of tobacco products, as defined herein;
2. Accept or redeem, offer to accept or redeem, or cause or hire any person to accept or redeem or offer to accept or redeem any coupon that provides any tobacco product, as defined herein, without charge or for less than the listed or non-discounted price; or
3. Sell a tobacco product, as defined herein, to consumers through any multi-pack discounts (e.g., "buy-two-get-one-free") or otherwise provide or distribute to consumers any tobacco product, as defined herein, without charge or for less than the listed or non-discounted price in exchange for the purchase of any other tobacco product.
4. Sections 2 and 3 shall not apply to products, such as cigarettes, for which there is a state law prohibiting them from being sold as loss leaders and for which a minimum retail price is required by state law.

4010 Out-of-Package Sales:

1. The sale or distribution of tobacco products, as defined herein, in any form other than an original factory-wrapped package is prohibited, including the repackaging or dispensing of any tobacco product, as defined herein, for retail sale. No person may sell or cause to be sold or distribute or cause to be distributed any cigarette package that contains fewer than twenty (20) cigarettes, including single cigarettes.

2. A retailer of Liquid Nicotine Containers must comply with the provisions of 310 CMR 30.000, and must provide the Wellfleet Board of Health with a written plan for disposal of said product, including disposal plans for any breakage, spillage or expiration of the product.
3. All retailers must comply with 940 CMR 21.05 which reads: “It shall be an unfair or deceptive act or practice for any person to sell or distribute nicotine in a liquid or gel substance in Massachusetts after March 15, 2016 unless the liquid or gel product is contained in a child-resistant package that, at a minimum, meets the standard for special packaging as set forth in 15 U.S. C.§§1471 through 1476 and 16 CFR §1700 et. Seq.”

4011 Self-Service Displays:

All self-service displays of tobacco products, as defined herein, are prohibited. All humidors including, but not limited to, walk-in humidors must be locked.

4012 Vending Machines:

All vending machines containing tobacco products, as defined herein, are prohibited.

4013 Non-Residential Roll-Your-Own Machines:

All Non-Residential Roll-Your-Own machines are prohibited.

4014 Prohibition of the Sale of Tobacco Products by Health Care Institutions:

No health care institution located in Wellfleet shall sell or cause to be sold tobacco products, as defined herein. No retail establishment that operates or has a health care institution within it, such as a pharmacy, optician/optometrist or drug store, shall sell or cause to be sold tobacco products, as defined herein.

4015 Prohibition of the Sale of Tobacco Products by Educational Institutions:

No educational institution located in Wellfleet shall sell or cause to be sold tobacco products, as defined herein. This includes all educational institutions as well as any retail establishments that operate on the property of an educational institution.

4016 Incorporation of Attorney General Regulation 940 CMR 21.00:

The sale or distribution of tobacco products, as defined herein, must comply with those provisions found at 940 CMR 21.00 (“Sale and Distribution of Cigarettes, Smokeless Tobacco Products, and Electronic Smoking Devices in Massachusetts”).

4017 Violations:

1. It shall be the responsibility of the establishment, permit holder and/or his or her business agent to ensure compliance with all sections of this regulation. The violator shall receive:
 - a. In the case of a first violation, a fine of one hundred dollars (\$100.00).
 - b. In the case of a second violation within 24 months of the date of the current violation, a fine of two hundred dollars (\$200.00) and the Tobacco Product Sales Permit shall be suspended for seven (7) consecutive business days.

- c. In the case of three or more violations within a 24 month period, a fine of three hundred dollars (\$300.00) and the Tobacco Product Sales Permit shall be suspended for thirty (30) consecutive business days.
- d. In the case of four violations or repeated, egregious violations of this regulation within a 24 month period, the Board of Health shall hold a hearing in accordance with subsection 4 of this section and may permanently revoke a Tobacco Product Sales Permit.

2. Refusal to cooperate with inspections pursuant to this regulation shall result in the suspension of the Tobacco Product Sales Permit for thirty (30) consecutive business days.

3. In addition to the monetary fines set above, any permit holder who engages in the sale or distribution of tobacco products while his or her permit is suspended shall be subject to the suspension of all Board of Health issued permits for thirty (30) consecutive business days.

4. The Wellfleet Board of Health shall provide notice of the intent to suspend or revoke a Tobacco Product Sales Permit, which notice shall contain the reasons therefor and establish a time and date for a hearing which date shall be no earlier than seven (7) days after the date of said notice. The permit holder or its business agent shall have an opportunity to be heard at such hearing and shall be notified of the Board of Health's decision and the reasons therefor in writing. After a hearing, the Wellfleet Board of Health may suspend or revoke the Tobacco Product Sales Permit if the Board of Health finds that a violation of this regulation occurred. For purposes of such suspensions or revocations, the Board shall make the determination notwithstanding any separate criminal or non-criminal proceedings brought in court hereunder or under the Massachusetts General Laws for the same offense. All tobacco products, as defined herein, shall be removed from the retail establishment upon suspension or revocation of the Tobacco Product Sales Permit. Failure to remove all tobacco products, as defined herein, shall constitute a separate violation of this regulation.

4018 Non-Criminal Disposition:

Whoever violates any provision of this regulation may be penalized by the non-criminal method of disposition as provided in Massachusetts General Laws, Chapter 40, Section 21D or by filing a criminal complaint at the appropriate venue.

4019 Separate Violations: Each day any violation exists shall be deemed to be a separate offense.

4020 Enforcement:

Enforcement of this regulation shall be by the Wellfleet Board of Health or its designated agent(s).

Any resident who desires to register a complaint pursuant to the regulation may do so by contacting the **Wellfleet** Board of Health or its designated agent(s) and the Board shall investigate.

4021 Severability:

If any provision of this regulation is declared invalid or unenforceable, the other provisions shall not be affected thereby but shall continue in full force and effect.

5000 REGULATIONS OF THE STATE OF MASSACHUSETTS

The following regulations are incorporated into this document:

- A. 105 CMR 123.000, Tanning Facilities
- B. 105 CMR 410.000, Minimum Standards of Fitness for Human Habitation: State Sanitary Code, Chapter II
- C. 310 CMR 22.00, Massachusetts Drinking Water Regulations
- D. 310 CMR 15.000, State Environmental Code, Title 5
- E. 105 CMR 590.000 – 595.000, Vending Machines and State Sanitary Code for Food Establishments, Article X
- F. 105 CMR 435.000, State Sanitary Code, Chapter V, Minimum Standards for Swimming Pools.

6000 TEMPORARY REGULATIONS

6001 (Moratorium adopted 12/16/85 by the Board of Selectmen acting as the Board of Health on approval of well and septic system permits on certain parcels of land.) Regulation rescinded in its entirety.

7000 PROCEDURES

7001 The Board of Health shall establish fees for the activities under its jurisdiction, and maintain, for public inspection, a current schedule of such fees.

7002 Variances

Requests for variance from Title 5 and/or the Wellfleet Board of Health Regulations must be made in writing, and must state the specific variance(s) sought and the reasons therefore. This letter shall be accompanied by a list of all abutters. Abutters are to be notified by the applicant per current Board of Health procedures of the time and place of the hearing during which the request will be heard. (Abutters must be notified 10 days in advance of the hearing by certified mail and proof of notification must be presented at the time of the hearing.) When the applicant wishes to install a septic system, the letter requesting the variance(s) shall be accompanied by (1) an application for a Disposal Works Construction Permit and payment for said permit, (2) engineered plans for the proposed disposal system, (3) floor plans for the building(s) to be served, (4) well water test results, (5) well construction record when a new well is involved. These materials must be in the Health Department at 12:00 PM a minimum of 1 week prior to the meeting date.

7003 Violations

When the Board of Health/Health Agent considers a regulation is being violated penalties will be initiated as follows:

- A. **Criminal Complaint** – Whoever violates any provision of these rules and regulations may be penalized by indictment or on complaint brought in District Court. Except as may otherwise be provided by law, and, as District Court may see fit to impose, the maximum penalty for any violation of these provisions shall be \$300 for each offense.
- B. **Non-Criminal Disposition** – Whoever violates any provision of these rules and regulations may, in the discretion of the Health Agent, be penalized by a non-criminal complaint in District Court pursuant to the provisions of General Laws, Chapter 40, Section 21D. For the purpose of this provision, any person who violates any provision of these regulations, or any condition issued pursuant to it shall be punished by a fine of not more than \$200.00. Each day on which a violation exists shall be deemed to be a separate offense.
- C. **Violation of Board of Health Regulations** may result in the suspension, revocation or alteration of local licenses or permits. (Alterations may include restrictions based on occupancy loading, including, but not necessarily limited to the number of bedrooms, restaurant seats or other mechanisms of protecting public health.

7004 Any person aggrieved by a decision of the Board of Health, or by the failure of the Board to act, may appeal to Superior Court, Barnstable County, pursuant to the provisions of Massachusetts General Laws.

8000 FEE SCHEDULE
(revised 8/7/08)

Permit Type	Fee
Commercial Septic Const. Permit - New Construction	\$150.00
- Varianced	\$250.00
- Upgrade	\$100.00
- Simple Repair	\$75.00
Residential Septic Const. Permit - New Construction	\$125.00
- Varianced	\$200.00
- Upgrade	\$75.00
- Simple Repair	\$50.00
Real Estate Transfer Septic Waiver	\$100.00
Real Estate Transfer Oil Tank Waiver	\$150.00
Septic Re-Inspection	\$50.00
Well Construction/Replacement Permit	\$50.00
Soil Evaluation (Perc Test)	\$100.00
Installer's Exam	\$25.00
Housing Inspection/ Field Determination, Per unit	\$60.00
Food Establishment	
0-50 Seats	\$100.00
51-100 Seats	\$150.00
Over 100 Seats	\$200.00
Temporary Food Establishment	\$25.00 per calendar day
Frozen Dessert Manufacturer	\$25.00
Mobil Food Service Vendor (Prepared Foods)	\$100.00
Mobil Food Service Vendor (Packaged Foods)	\$75.00
Retail Food	\$100.00
Retail Food / Food Service Establishment	\$150.00
Septic Installers	\$100.00
Septage Haulers	\$100.00
Refuse Haulers	\$100.00
Motel/Cabin/Trailer Park Permit	\$50.00
Recreational Camp For Children	\$50.00
Commercial Pool Permit	\$100.00
Residential Pool Installation Permit	\$50.00
Tobacco	\$100.00
Funeral Director	\$100.00
Animal Permit, Per animal or per 3 fowl	\$3.00
Stable Permit	\$25.00
Tanning Facility	\$200.00
Body Art Establishment	\$600.00
Body Art Practitioner	\$400.00 per person

**Town of Wellfleet
Board of Health
Schedule of Fees and Conditions for Solid Waste Disposal
at the Wellfleet Transfer Station
EFFECTIVE 7/1/2016**

Residential Waste Disposal

1. Resident Vehicle Sticker

A.	1 st vehicle.....	\$25.00
B.	2 nd vehicle.....	\$10.00
C.	3 rd vehicle.....	\$35.00

Stickers are to be permanently affixed to the upper part of the exterior of the rearmost side window on the driver's side of the vehicle, and allow unlimited entry for disposal of reasonable quantities of ordinary household waste from a single residence only. All waste must be in Wellfleet designated "Pay as You Throw" bags.

2. Pay As You Throw Bags

A.	large (about 33 gallons).....	\$1.50
B.	medium (about 15 gallons).....	\$1.00
C.	small (about 8 gallons).....	\$.50

3. One Time User Fee.....\$5.00/bag

Pay as You Throw bags not required however, there is a 35 gallon bag limit.

Commercial Waste Disposal

1. Commercial Business Vehicle Sticker

A.	small vehicle (<1 ton).....	\$65.00
B.	large vehicle (>1 ton).....	\$95.00

Disposal of waste from hotels, motels, cottage colonies, condominiums, restaurants, and commercial businesses requires a commercial business vehicle sticker.

2. Commercial Refuse Fee

A.	waste in Pay as You Throw bags.....	free
B.	waste not in Pay as You Throw bags.....	\$120.00/ton

Commercial Refuse Hauler

1. Commercial Refuse Hauler Vehicle Sticker.....\$95.00

2. Commercial Refuse Hauler Residential Refuse Fee.....\$30.00/ton

If waste is to be disposed of at the Wellfleet Transfer Station it is required to be in Wellfleet designated "Pay as You Throw" bags.

Construction and Demolition Disposal

1. Construction and Demolition Disposal Fee.....\$270.00/ton

Construction and demolition includes sheet rock, bricks, asphalt, shingles, windows, doors, and scrap lumber which is cut into six foot lengths.

Bulk Metal

1. Bulk Metal Disposal Fee.....\$40.00/ton

Special Fee Items

Appliances	\$10.00 each
Carpets	\$10.00 each
50 Gallon Drums	\$5.00 each
Mattresses and Box Spring	\$20.00 each
Petroleum Tanks-300 Gallons	\$30.00 each
Propane Tanks- 20 lb Capacity	\$3.00 each
Propane Tanks- >20 lb Capacity	\$20.00 each
Sofas and Chairs	\$10.00 each
Televisions and Computer Monitors	\$10.00 each
Car Tires	\$2.00 each
Truck Tires	\$5.00 each
Water Tanks	\$5.00 each
Toilets	\$5.00 each
Fire Extinguishers	\$6.00 each
Other Bulky Items	\$10.00 each

THERE WILL BE NO FEE FOR RECYCLABLE MATERIALS

ATTACHMENT A

RECYCLING

The following items must be separated for recycling and are accepted at the Transfer Station:

PAPER

- Newspapers / inserts
- Corrugated cardboard, flattened
- No soiled paper
- No plastic bags or waxed cardboard

GLASS

- Glass bottles and jars – clear, green and brown
- Rinse clean, remove lids and corks but neck rings, collars & labels may stay on
- No broken glass or other glass items such as window glass, mirrors, dishes, glasses, Pyrex, ceramics, or light bulbs

METAL

- Tin, steel and aluminum cans and lids
- Deposit and non-deposit beverage cans
- No aluminum foil
- Rinse clean, may flatten, labels may stay on
- No cans containing aerosol or paint

PLASTIC

- Plastic containers labeled 1 and 2 (check bottom of container for number)
- Empty and rinse containers clean, flatten
- No plastic bags or unmarked plastic

YARD WASTE

- Grass, leaves and other easily raked material, loose only – no bags
- Christmas trees
- Branches no larger than 6' length and 2" diameter
- No stumps or vines

BULK METAL

- Large metal items, all rubber removed / extra fee applies
- Appliances – remove doors / extra fee applies

AUTOMOTIVE

- Tires – remove rims / extra fee applies
- Car batteries
- Motor oil
- Antifreeze

SCRAP WOOD

- Clean wood only – no paint or nails
- No particle board

PAINT

- Latex and oil based paints and stains

HORSE MANURE

- One ton of residential horse manure per customer per day
- Manure must be produced from horses with a vegetarian diet

***Wellfleet Board of Health
Hybrid Meeting
Zoom/715 Old King's Highway
Wednesday August 10, 2022; 5:30pm
Meeting Minutes***

Members Present: Ken Granlund, Chair; Janet Drohan, Nick Picariello, Deborah Freeman, (virtual); Gary Locke (virtual)

Others Present: Hillary Greenberg Lemos, Health Agent; Meredith Ballinger, Assistant Health Agent; Rebekah Eldridge (virtual), Committee Secretary; Scott Horsley, Town consultant; Curt Felix, Chair of the Clean Water Advisory Committee; Jude Ahern, resident; Kathleen Bacon, Wellfleet Selectboard Member; John Cumbler, Wellfleet Resident.

Chair Granlund called the meeting to order at 5:33pm

Reorganization of the Board

Chair Granlund stated he had been the chair of the board for many years and would like to pass the “baton”.

Board Member Drohan Moved; Board Member Freeman seconded; and it was voted to appoint Dr. Nick Picariello as the chair of the board of health.

Roll Call Vote: 5-0

Wellfleet Board of Health Rules and Regulations

Chair Picariello spoke to the board and the public and stated that the board would be discussing the regulations.

Horsley presented a slide show to the board and public. He spoke about the targeted watershed plan and explained the timeline to the board. Horsley stated to the board that the Wellfleet Selectboard did approve this plan and it was recently submitted to Mass department of environmental protection.

He spoke about the goals of a targeted watershed plan and stated to the board that this would be the second plan in the state of Massachusetts. Horsley showed a pie chart that explained high nitrogen levels in the town, he showed maps of the town and areas that the town would benefit from. His slide show gave a great deal of information with regard to the watershed permit and the planned sewer system throughout the Main Street downtown area. The presentation lasted about 20 minutes and he ended the presentation by stating that all the information at tonight’s meeting is on the towns website for anyone to review.

It was then opened to the audience for comments or suggestions.

Curley spoke to the board about the watershed permit, he stated that means the DEP is updating their title 5 septic regulations. He gave some statistics on septic systems and cesspools around the town. Horsley spoke to Curley’s questions and comments. The board discussed the

regulations in further detail. Ahern spoke to the board stating that the IA system she purchased was very expensive and needs to be updated. Horsley tried to answer some of Jude's questions. The board moved on and discussed the sewer district asking Horsley to pull up the slide that shows the core area (downtown) for the sewer system.

Curley had more comments and questions for the board, they discussed all questions in great length.

Lemos then shared her screen to show the board and public the changes being made to the Wellfleet Regulations. She stated section 600 of the regulations is what the board will be discussing and reviewing tonight. She stated there will be more than one public hearing. She continued going over the amendments to the regulations and answered any questions that came up. Bacon questioned if Lemos and the board had considered vernal pools in the regulation's amendments, Lemos stated that yes, she had done so, she continued reviewing with the board and public the amended regulations.

The board explained to the public that with every variance they are presented with, they do review each as a case by case basis. There will be a tax insert to inform the public about the public hearing on November 9, 2022. It will be posted on the town's website.

Eldridge informed the board that the tax insert will be on the consent agenda for the following meeting. Cumbler spoke to the board about making this upgrade happen sooner rather than later, and felt the longer the regulation takes to go into effect the longer it will take the town to reach its goals.

They discussed how long it will take effect to have these regulations go into effect. Lemos stated that as soon as the board has their public hearing and take a vote on the amended regulations then they will go into effect.

**Drohan Moved; Picariello Seconded; and it was voted to adjourn.
Meeting Adjourned 7:22pm**

Public Documents:

Draft Wellfleet Board of Health Rules and Regulations

Power point presentation of the targeted watershed plan for the town of Wellfleet.

Wellfleet Board of Health
Wednesday August 24, 2022; 5:30pm
Hybrid Meeting ~
715 Old King's Highway/Zoom
Meeting Minutes

Members Present: Nick Picariello, Chair; Janet Drohan, Debbie Freeman, Gary Locke (virtual); Ken Granlund (virtual)

Others Present: Hillary Greenberg-Lemos, Health Agent; Rebekah Eldridge (virtual), Board Secretary; Harry Terkanian, Chair of the Wellfleet Affordable Housing Trust; Ryan Curley, Chair of the Selectboard; Richard Waldo, Town Administrator; John Gauthier, co-owner for Maurice's Campground; Curt Felix, Chair of the Clean Water Advisory Committee.

Variations:

- 80 State Highway; Wellfleet MA; Maurice's Campground; Map #47, Parcel #23
The Wellfleet Selectboard has requested multiple variances for the possible purchase of the campground.

Terkanian presented to the board requesting that the Board of Health relieve the groups ask to keep the campground running for the next six years so that it can continue as a campground and reduce the cost to the town. He gave details to the board on how the affordable housing came to the owners of the campground showing interest in purchasing the property. He explained to the board how the deal began and when the negotiation started with the Gauthiers for the property and didn't want to burden them with the need to upgrade the cesspools, giving details on the pumping of the cesspools on the property. The board had some questions for Terkanian questioning if he was certain that the campground would go any longer than the six-years, Terkanian explained that this was in the original contract.

Drohan explained her concerns, stating she supports the purchase of this property and explained that she will vote for this at town meeting, explaining that although she supports this, she has a duty to advocate for the residents of Wellfleet and the water that is in Wellfleet. Each board member spoke of their concerns in leaving 35 cesspools on this property for the next 6 years, stating this is a tough call for them.

Freeman spoke to the regulations that the board is now beginning to put into place that will require homeowners who have cesspools a two-year timeline to replace their cesspools with IA septic systems. They all agreed that the Board wasn't given enough time to even consider this and felt it very rushed on them.

The board discussed cesspools, their life spans, and the soil that they are sitting in. Curley spoke to the board about the goals of the town and the goals the town is trying to set forth for this campground making it permanent housing for the town and the employees of the town that rely on that housing. He continued addressing some of the board's concerns,

speaking about the fact that right now there is no contamination, the cesspools are tested, the water has been tested and passed.

Lemos questioned if there was any money available to hire an engineering firm to have a look at the property and investigate and do some testing to see what exactly is there.

Curley explained that this would need to be an article on town meeting. He spoke about some of the money that the town has received to see if the town will be able to use this money for this project.

Waldo spoke to the group asking them to consider this a special circumstance, realizing this was a tough ask for this board. The board spoke to having a site plan. Money was discussed and how the town would be able to afford the site plan. Felix spoke to the board stating that there is money available, and it would just need to be applied for. The board is looking for more details and where the AARPA funds would go. Curley asked the board if they would be willing to help with the scope of work.

Gauthier spoke to the board explaining that both the trailer parks in the town were given ample time to upgrade their septic and water systems. He gave the board some of the campground's statistics, including water quality and pumping records throughout the years of the campground. The board stated how supportive they were for this project but explained that the obstacles that stand in front of them are great!

The discussion continued on how to make this project move forward and both groups being able to work together as a team to get this project moving forward.

Lemos read two letters that were sent in from Michael DeVasto a member of the Selectboard, and the Selectboard from the Town of Eastham. DeVasto spoke to the group talking about the cesspools and septic systems on the campground are not used year-round, so the pumping is a lot less than regularly used cesspools and septic systems. The discussion continued with the board and the audience. Curley spoke to the board asking them finally to please consider this proposition and thanked them for their time and consideration.

NO ACTION WAS TAKEN

Board Member Freeman Moved; Board Member Drohan Seconded; and it was voted to adjourn.

Roll Call Vote: 5-0

Meeting Adjourned 6:50pm

Wellfleet Board of Health
Hybrid Meeting
Zoom/715 Old King's Highway
Wednesday September 7, 2022; 5pm
Meeting Minutes

Members Present: Nick Picariello, Chair; Ken Granlund, Janet Drohan, Deb Freeman

Others Present: Hillary Greenberg-Lemos, Health Agent; Rebekah Eldridge, Committee Secretary; Ryan Curley, Chair of the Selectboard; Curt Felix, Chair of the Clean Water Committee. Ryan Stern, abutter; Rich Waldo, Town Administrator; Kathleen Bacon, Member of the Selectboard; Michael DeVasto, Member of the Selectboard; James Day, abutter; Jaquelyn Beebe, Town Administrator of Eastham (abutter); Mary Ellen Dwyer, abutter; Gail Ray, abutter; Karen Murphy, abutter, town tax collector; Rich Murphy, abutter to Maurice's Camoground.

Chair Picariello called the meeting to order at 5:03pm

Variances:

80 State Highway; Maurice's Campground Wellfleet MA Map #47, Parcel #23

The Wellfleet Selectboard has requested multiple Variances for this parcel of land. The Board of Health has met on this variance request once and will continue discussion on the variiances requested.

- Chair Picariello spoke to the public stating that the agenda has changed and that the Board of Health has no jurisdiction over the campground and the variiances being sought after by the town. He asked Lemos to explain the current situation

Lemos spoke to the public explaining that due to the number of gallons per day at the campground exceeds a certain amount the Massachusetts Department of Environmental Protection is the body that will be able to allow the variance.

Felix got up and spoke to the public body which consisted mostly of abutters to the campground, He gave them a better understanding of the plan that is being sought. The board explained again that they can't make a vote on this project or variiances requested by the town.

Curley asked the board to support this purchase and the board stated that they could only do so at town meeting.

Lemos explained the details of how the board can move forward working with DEP.

Curley spoke to the plan and the schedule the town expects to follow.

It was questioned the worst-case scenario, where the DEP doesn't pass the variiances. It was stated that if they didn't pass what the town was looking for, they would allow certain gallons per day.

There were many questions directed to the board, Curley, and Felix regarding the plan for the campground.

Waldo spoke to the board virtually stating that there is concern throughout administration and there is an outlook to improve and build on these issues. He stated they will work on

how the town does not get themselves in a situation where they aren't bound by the DEP or the purchase and sales agreement with the owners of the campground. He stated there will be discussion on this and the town is working on this.

Bacon spoke to the board thanking them for their thoughtfulness and comments on this project. She spoke to the importance of housing in Wellfleet. She agreed with Lemos stating that having this project in the hands of the DEP will help make sure this is a safe process and is pleased that this full decision doesn't fall on the shoulders of the Board of Health.

DeVasto spoke to the board stating that the cesspools on the property are not in use year-round and are only used for less than six-months a year he explained that the nitrogen loading issues aren't as detrimental as some might think. He spoke to the many septic systems throughout the town that aren't pumped as regularly.

There were no other questions from the abutters, Curley spoke to the board and stated that the last meeting was helpful allowing the town to go back to the drawing board so they could rewrite the variance request. He asked the board if they have any advice for the town moving forward with the DEP. The wetland delineation is a concern and he stated that they would like to do a full site survey once the town was purchased by the town. Two consultants would be hired to help with this site.

Lemos questioned the boat storage area regarding the soils and or contamination of that area. Curley stated they will be taking soil samples around the area of the boat storage and the cesspool area.

Phase 1 is completed, and it will be emailed to the board.

Freeman spoke to Curley and asked for a regular set of meetings so that the board isn't caught off guard again and have something so significant dropped in their laps. Curley explained that town counsel had recommended that the Selectboard not go to the Board of Health until after the purchase was announced.

Stern spoke to the board and public stating that the communication to the abutters hasn't been significant. He stated he wants a better presentation as to what the plans are for this property. He continued stating that there are so many unknowns for the abutters and residents of the town.

He asked for a list of the unknowns and more transparency. Lemos read a letter from abutters, from the Rice's.

Beebe spoke to the board thanking them for their due diligence and spoke to the complicated issues. She stated she agreed with transparency.

Dwyer spoke to the board and public, with some concerns about lighting, fencing and trees, the septic issue stating that she has a well and wants her water supply to be safe.

Bacon spoke to the lighting questions, stating she was on the 95 Lawrence Task Force and stated that in the RFP the group was able to delineate design details allowing for all these issues. Stating there will be outreach to the residents for comments.

Murphy spoke to the board asking for regulations of trailer parks and if there was documentation with water tests.

Mr. Murphy spoke to the board stating that he is for the town purchasing the property given the alternative however he has concerns and knows there are more questions. The board discussed this further and repeated that they don't have jurisdiction over this property but was grateful to the public for sharing their thoughts and concerns.

NO ACTION WAS TAKEN

Drohan Moved, Freeman Seconded; and it was voted to adjourn

Roll Call Vote: 4-0

Meeting Adjourned 6:15pm

Wellfleet Board of Health
Hybrid Meeting
Zoom/715 Old Kings Highway (ACC)
Wednesday September 14, 2022; 5:30pm
Meeting Minutes

Members Present: Nick Picariello, Chair; Ken Granlund, Vice Chair; Janet Drohan, Deb Freeman

Members Absent: Gary Locke

Others Present: Hillary Greenberg-Lemos, Health Agent; Rebekah Eldridge, Committee Secretary; Meredith Ballinger, Assistant Health Agent, Matt Farrell, J.M. O'Reilly representative for Samoset Ave. and Hiller Ave.; Stephanie Sequin, Ryder & Wilcox representative; Deborah Ganes, Resident

Chair Picariello called the meeting to order at 5:30pm

Variances:

- 107 & 113 Samoset Avenue, Wellfleet, MA 02667; Maps #28 & Parcels #108, 109 Farrell presented to the board asking for variances. He explained why the variances were being asked. Lemos stated that the water testing was good. The board discussed this variance with Lemos and Farrell.

Board Member Granlund Moved, Board Member Drohan Seconded; and it was voted to approve J.M. O'Reilly plan #9233 dated September 1, 2022 and grant the 7 variances requested in the letter dated September 1, 2022, for the upgrade of a septic system to serve a 4 bedroom structure, a grandfathered nonconforming dwelling; using nitroe denitrification technology under the provisional use approval category. Floor plans to be reviewed by the health agent.

Subject to the following conditions:

Design flow to be limited to 400 GPD, to serve 4 bedrooms

No increase in habitable area without Board of Health review

No conversion of use without Board of Health review

Well water to be tested

A deed recording to be filed with the Barnstable registry of deeds

I/A monitoring to be done

- 43 Hiller Avenue, Wellfleet MA 02667, Map #20, Parcel #128
Farrell spoke to this property and explained the plans that were in front of the board. The board discussed this with Farrell and the issues they had with this plan. Lemos read a section of the Department of Environmental Protection to the board. After much discussion, Farrell asked for a continuance on this variance so he could research on the system. Lemos asked for a note if the leach field needs to be replaced to add it to the plan.

Board Member Freeman Moved; Board Member Drohan Seconded; and it was voted to continue this variance to the October 12, 2022 meeting.

Roll Call Vote: 4-0

Discussion

- 55 Harvard Street Wellfleet MA 02667, Map #36, Parcel #67 & 44 Cypress Street Wellfleet, MA 02667, Map #36, Parcel #78
Lemos explained the paperwork the board had in front of them which was nitrate testing on these properties. She explained the maps to the board, and they discussed the property. Sequin spoke on behalf of the property owner and both properties. She stated the 55 Harvard Street owners use this property very little and don't know where the nitrogen has been coming from. Chair Picariello questioned the boards options.
Chair Picariello Moved; Board Member Drohan Seconded; and it was voted to sample the abutting well at 44 Cypress Street Map #36, Parcel #78 quarterly for one year and reevaluate at that point if an upgrade is warranted.

Drohan spoke to board members asking for a Selectboard Liaison so that they are able to be a part of what is happening with the Board.

Eldridge will put it on the next Selectboard agenda for review.

Wellfleet Board of Health Rules and Regulations

- The Board will continue discussion on amending the regulations for the town. The Board may possibly set a public hearing date
The board discussed the amended rules and regulations. Lemos reported there is a public meeting on November 9, 2022.
Ganes spoke to the board as a seasonal resident in Wellfleet. She read a statement to the board regarding the updated regulations. The board took notes and discussed Ganes' comments.

Minutes

- April 13, 2022 – **Board Member moved, Board Member Seconded; and it was voted to approve the meeting minutes as printed in draft.**
Roll Call Vote: 4-0
- May 11, 2022 - **Board Member moved, Board Member Seconded; and it was voted to approve the meeting minutes as printed in draft.**
Roll Call Vote: 4-0
- July 20, 2022 - **Board Member moved, Board Member Seconded; and it was voted to approve the meeting minutes as printed in draft.**
Roll Call Vote: 4-0

Adjournment

Drohan Moved; Freeman Seconded; and it was voted to adjourn.

Roll Call Vote: 4-0

Meeting Adjourned: 6:40pm